

S2

Answers & Solutions

for

NEET (UG) - 2019

Time : 3 hrs.

Max. Marks : 720

Important Instructions :

1. The test is of **3 hours** duration and Test Booklet contains **180** questions. Each question carries **4** marks. For each correct response, the candidate will get **4** marks. For each incorrect response, **one mark** will be deducted from the total scores. The maximum marks are **720**.
2. Use **Blue / Black Ball point Pen only** for writing particulars on this page/markings responses.
3. Rough work is to be done on the space provided for this purpose in the Test Booklet only.
4. On completion of the test, the candidate must handover the Answer Sheet to the Invigilator before leaving the Room / Hall. *The candidates are allowed to take away this Test Booklet with them.*
5. The CODE for this Booklet is **S2**.
6. The candidates should ensure that the Answer Sheet is not folded. Do not make any stray marks on the Answer Sheet. Do not write your Roll No. anywhere else except in the specified space in the Test Booklet/Answer Sheet.
7. Each candidate must show on demand his/her Admission Card to the Invigilator.
8. No candidate, without special permission of the Superintendent or Invigilator, would leave his/her seat.
9. Use of Electronic/Manual Calculator is prohibited.
10. The candidates are governed by all Rules and Regulations of the examination with regard to their conduct in the Examination Hall. All cases of unfair means will be dealt with as per Rules and Regulations of this examination.
11. No part of the Test Booklet and Answer Sheet shall be detached under any circumstances.
12. The candidates will write the Correct Test Booklet Code as given in the Test Booklet / Answer Sheet in the Attendance Sheet.

- From evolutionary point of view, retention of the female gametophyte with developing young embryo on the parent sporophyte for some time, is first observed in
 - Pteridophytes
 - Gymnosperms
 - Liverworts
 - Mosses

Answer (1)

Sol. In Pteridophyte, megaspore is retained for some times in female gametophyte, however the permanent retention is required for seed formation in Gymnosperms.

That's why Pteridophytes exhibit precursor to seed habit only.

- Extrusion of second polar body from egg nucleus occurs :
 - before entry of sperm into ovum
 - simultaneously with first cleavage
 - after entry of sperm but before fertilization
 - after fertilization

Answer (3)

Sol. Extrusion of second polar body from egg nucleus occurs after entry of sperm but before fertilization.

The entry of sperm into the ovum induces completion of the meiotic division of the secondary oocyte.

Entry of sperm causes breakdown of metaphase promoting factor (MPF) and turns on anaphase promoting complex (APC).

- DNA precipitation out of a mixture of biomolecules can be achieved by treatment with
 - Methanol at room temperature
 - Chilled chloroform
 - Isopropanol
 - Chilled ethanol

Answer (4)

Sol. During the isolation of desired gene, chilled ethanol is used for the precipitation of DNA.

- Due to increasing air-borne allergens and pollutants, many people in urban areas are suffering from respiratory disorder causing wheezing due to
 - proliferation of fibrous tissues and damage of the alveolar walls
 - reduction in the secretion of surfactants by pneumocytes.
 - benign growth on mucous lining of nasal cavity
 - inflammation of bronchi and bronchioles

Answer (4)

Sol. Asthma is a difficulty in breathing causing wheezing due to inflammation of bronchi and bronchioles. It can be due to increasing air born allergens and pollutants. Asthma is an allergic condition. Many people in urban areas are suffering from this respiratory disorder.

- The Earth Summit held in Rio de Janeiro in 1992 was called
 - to assess threat posed to native species by invasive weed species
 - for immediate steps to discontinue use of CFCs that were damaging the ozone layer
 - to reduce CO₂ emissions and global warming
 - for conservation of biodiversity and sustainable utilization of its benefits

Answer (4)

Sol. Earth Summit (Rio Summit)-1992, called upon all nations to take appropriate measures for conservation of biodiversity and sustainable utilisation of its benefits

- Match the hominids with their correct brain size :

| | |
|----------------------------------|------------------|
| (a) <i>Homo habilis</i> | (i) 900 cc |
| (b) <i>Homo neanderthalensis</i> | (ii) 1350 cc |
| (c) <i>Homo erectus</i> | (iii) 650-800 cc |
| (d) <i>Homo sapiens</i> | (iv) 1400 cc |

Select the correct option.

- | | | | | |
|-----|-------|-------|------|------|
| | (a) | (b) | (c) | (d) |
| (1) | (iii) | (iv) | (i) | (ii) |
| (2) | (iv) | (iii) | (i) | (ii) |
| (3) | (iii) | (i) | (iv) | (ii) |
| (4) | (iii) | (ii) | (i) | (iv) |

Answer (1)

Sol. The correct match of hominids and their brain sizes are :

| | | |
|------------------------------|---|------------|
| <i>Homo habilis</i> | — | 650-800 cc |
| <i>Homo neanderthalensis</i> | — | 1400 cc |
| <i>Homo erectus</i> | — | 900 cc |
| <i>Homo sapiens</i> | — | 1350 cc |

7. How does steroid hormone influence the cellular activities?

- (1) Activating cyclic AMP located on the cell membrane
- (2) Using aquaporin channels as second messenger
- (3) Changing the permeability of the cell membrane
- (4) Binding to DNA and forming a gene-hormone complex

Answer (4)

Sol. Steroid hormones directly enter into the cell and bind with intracellular receptors in nucleus to form hormone receptor complex. Hormone receptor complex interacts with the genome

8. Expressed Sequence Tags (ESTs) refers to :

- (1) DNA polymorphism
- (2) Novel DNA sequences
- (3) Genes expressed as RNA
- (4) Polypeptide expression

Answer (3)

Sol. Expressed Sequence Tags (ESTs) are DNA sequences (genes) that are expressed as mRNA for protein synthesis. These are used in human Genome Project.

9. It takes very long time for pineapple plants to produce flowers. Which combination of hormones can be applied to artificially induce flowering in pineapple plants throughout the year to increase yield?

- (1) Gibberellin and Abscisic acid
- (2) Cytokinin and Abscisic acid
- (3) Auxin and Ethylene
- (4) Gibberellin and Cytokinin

Answer (3)

Sol. Plant hormone auxin induces flowering in pineapple. Ethylene also helps in synchronization of flowering and fruit set up in pineapple.

10. Which of the following ecological pyramids is generally inverted?

- (1) Pyramid of biomass in a forest
- (2) Pyramid of biomass in a sea
- (3) Pyramid of numbers in grassland
- (4) Pyramid of energy

Answer (2)

Sol. In an aquatic ecosystem, the pyramid of biomass is generally inverted.

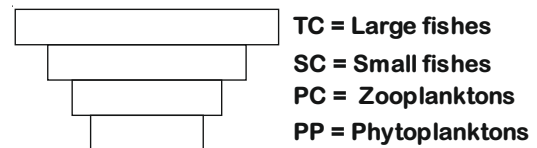

11. Which of the following pair of organelles does not contain DNA?

- (1) Lysosomes and Vacuoles
- (2) Nuclear envelope and Mitochondria
- (3) Mitochondria and Lysosomes
- (4) Chloroplast and Vacuoles

Answer (1)

Sol. Lysosomes and Vacuoles do not have DNA.

12. Select the correct sequence for transport of sperm cells in male reproductive system.

- (1) Seminiferous tubules → Vasa efferentia → Epididymis → Inguinal canal → Urethra
- (2) Testis → Epididymis → Vasa efferentia → Vas deferens → Ejaculatory duct → Inguinal canal → Urethra → Urethral meatus
- (3) Testis → Epididymis → Vasa efferentia → Rete testis → Inguinal canal → Urethra
- (4) Seminiferous tubules → Rete testis → Vasa efferentia → Epididymis → Vas deferens → Ejaculatory duct → Urethra → Urethral meatus

Answer (4)

Sol. The correct sequence for transport of sperm cells in male reproductive system is Seminiferous tubules → Rete testis → Vasa efferentia → Epididymis → Vas deferens → Ejaculatory duct → Urethra → Urethral meatus

13. Match the following hormones with the respective disease

- | | |
|--------------------|-------------------------|
| (a) Insulin | (i) Addison's disease |
| (b) Thyroxin | (ii) Diabetes insipidus |
| (c) Corticoids | (iii) Acromegaly |
| (d) Growth Hormone | (iv) Goitre |
| | (v) Diabetes mellitus |

Select the correct option.

- | | | | |
|----------|------|-------|-------|
| (a) | (b) | (c) | (d) |
| (1) (v) | (iv) | (i) | (iii) |
| (2) (ii) | (iv) | (i) | (iii) |
| (3) (v) | (i) | (ii) | (iii) |
| (4) (ii) | (iv) | (iii) | (i) |

Answer (1)

Sol. • Insulin deficiency leads to diabetes mellitus

- Hypersecretion or hyposecretion of thyroxine can be associated with enlargement of thyroid gland called goitre
- Deficiency of corticoids (Glucocorticoid + mineralocorticoid) leads to Addison's disease
- Growth hormone hypersecretion in adults leads to Acromegaly

14. Persistent nucellus in the seed is known as

- | | |
|-------------|---------------|
| (1) Hilum | (2) Tegmen |
| (3) Chalaza | (4) Perisperm |

Answer (4)

Sol. Persistent Nucellus is called Perisperm

e.g.: Black pepper, Beet

15. *Pinus* seed cannot germinate and establish without fungal association. This is because :

- (1) it has very hard seed coat.
- (2) its seeds contain inhibitors that prevent germination.
- (3) its embryo is immature.
- (4) it has obligate association with mycorrhizae.

Answer (4)

Sol. Fungus associated with roots of *Pinus* increases minerals & water absorption for the plant by increasing surface area and in turn fungus gets food from plant. Therefore, mycorrhizal association is obligatory for *Pinus* seed germination

16. Cells in G_0 phase :

- (1) suspend the cell cycle
- (2) terminate the cell cycle
- (3) exit the cell cycle
- (4) enter the cell cycle

Answer (3)

Sol. Cells in G_0 phase are said to exit cell cycle. These are at quiescent stage and do not proliferate unless called upon to do so.

17. Match the following structures with their respective location in organs

- | | | |
|--------------------------|-------|-----------------|
| (a) Crypts of Lieberkuhn | (i) | Pancreas |
| (b) Glisson's Capsule | (ii) | Duodenum |
| (c) Islets of Langerhans | (iii) | Small intestine |
| (d) Brunner's Glands | (iv) | Liver |

Select the correct option from the following

- | | | | |
|-----------|------|------|-------|
| (a) | (b) | (c) | (d) |
| (1) (iii) | (iv) | (i) | (ii) |
| (2) (iii) | (ii) | (i) | (iv) |
| (3) (iii) | (i) | (ii) | (iv) |
| (4) (ii) | (iv) | (i) | (iii) |

Answer (1)

Sol. Crypts of Lieberkuhn are present in small intestine. Glisson's capsule is present in liver. Islets of langerhans constitutes the endocrine portion of pancreas. Brunner's glands are found in submucosa of duodenum.

18. Grass leaves curl inwards during very dry weather. Select the most appropriate reason from the following

- (1) Shrinkage of air spaces in spongy mesophyll
- (2) Tyloses in vessels
- (3) Closure of stomata
- (4) Flaccidity of bulliform cells

Answer (4)

Sol. Bulliform cells become flaccid due to water loss. This will make the leaves to curl inward to minimise water loss

19. Consider the following statements :
- (A) Coenzyme or metal ion that is tightly bound to enzyme protein is called prosthetic group.
- (B) A complete catalytic active enzyme with its bound prosthetic group is called apoenzyme.

Select the correct option.

- (1) Both (A) and (B) are false.
 (2) (A) is false but (B) is true.
 (3) Both (A) and (B) are true.
 (4) (A) is true but (B) is false.

Answer (4)

Sol. Coenzyme or metal ion that is tightly bound to enzyme protein is called prosthetic group. A complete catalytic active enzyme with its bound prosthetic group is called holoenzyme.

20. Respiratory Quotient (RQ) value of tripalmitin is
- (1) 0.07
 (2) 0.09
 (3) 0.9
 (4) 0.7

Answer (4)

Sol. Respiratory Quotient = $\frac{\text{Amount of CO}_2 \text{ released}}{\text{Amount of O}_2 \text{ consumed}}$ (RQ)

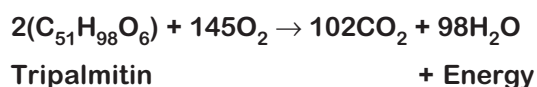

$$\text{RQ} = \frac{102 \text{ CO}_2}{145 \text{ O}_2} = 0.7$$

21. Which of the following statements is incorrect?
- (1) Infective constituent in viruses is the protein coat.
 (2) Prions consist of abnormally folded proteins.
 (3) Viroids lack a protein coat.
 (4) Viruses are obligate parasites.

Answer (1)

Sol. Infective constituent in viruses is either DNA or RNA, not protein.

22. Phloem in gymnosperms lacks :
- (1) Companion cells only
 (2) Both sieve tubes and companion cells
 (3) Albuminous cells and sieve cells
 (4) Sieve tubes only

Answer (2)

Sol. Phloem in Gymnosperms lacks both sieve tube and companion cells.

23. Under which of the following conditions will there be no change in the reading frame of following mRNA?

5' AACAGCGGUGCUAUU 3'

- (1) Insertion of A and G at 4th and 5th positions respectively
 (2) Deletion of GGU from 7th, 8th and 9th positions
 (3) Insertion of G at 5th position
 (4) Deletion of G from 5th position

Answer (2)

Sol.

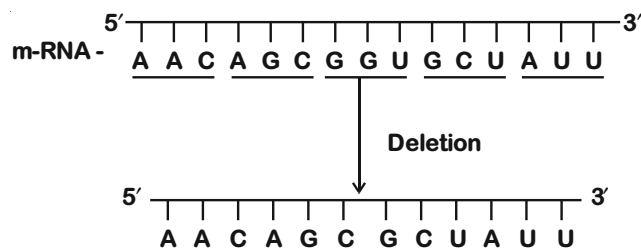

No change in reading frame of m-RNA.

24. Identify the cells whose secretion protects the lining of gastro-intestinal tract from various enzymes.
- (1) Oxyntic Cells (2) Duodenal Cells
 (3) Chief Cells (4) Goblet Cells

Answer (4)

Sol. Goblet cells secrete mucus and bicarbonates present in the gastric juice which plays an important role in lubrication and protection of the mucosal epithelium from excoriation by the highly concentrated HCl.

25. What is the site of perception of photoperiod necessary for induction of flowering in plants?
- (1) Shoot apex (2) Leaves
 (3) Lateral buds (4) Pulvinus

Answer (2)

Sol. Microbes are used in production of several household and industrial products –

Lactobacillus – Production of curd

Saccharomyces cerevisiae – Bread making

Aspergillus niger – Citric acid production

Acetobacter aceti – Acetic acid

33. Select the incorrect statement.

- (1) Inbreeding selects harmful recessive genes that reduce fertility and productivity
- (2) Inbreeding helps in accumulation of superior genes and elimination of undesirable genes
- (3) Inbreeding increases homozygosity
- (4) Inbreeding is essential to evolve purelines in any animal.

Answer (1)

Sol. Inbreeding exposes harmful recessive genes that are eliminated by selection. It also helps in accumulation of superior genes and elimination of less desirable genes. Therefore this is selection at each step, increase the productivity of inbred population. Close and continued inbreeding usually reduces fertility and even productivity.

34. Which of the following immune responses is responsible for rejection of kidney graft?

- (1) Inflammatory immune response
- (2) Cell-mediated immune response
- (3) Auto-immune response
- (4) Humoral immune response

Answer (2)

Sol. The body is able to differentiate self and nonself and the cell-mediated response is responsible for graft rejection.

35. Which of the statements given below is not true about formation of Annual Rings in trees?

- (1) Activity of cambium depends upon variation in climate.
- (2) Annual rings are not prominent in trees of temperate region.
- (3) Annual ring is a combination of spring wood and autumn wood produced in a year
- (4) Differential activity of cambium causes light and dark bands of tissue - early and late wood respectively.

Answer (2)

Sol. Growth rings are formed by the seasonal activity of cambium. In plants of temperate regions, cambium is more active in spring and less active in autumn seasons. In temperate regions climatic conditions are not uniform throughout the year. However in tropics climatic conditions are uniform throughout the year.

36. Which of the following is true for Golden rice?

- (1) It is drought tolerant, developed using *Agrobacterium* vector
- (2) It has yellow grains, because of a gene introduced from a primitive variety of rice
- (3) It is Vitamin A enriched, with a gene from daffodil
- (4) It is pest resistant, with a gene from *Bacillus thuringiensis*

Answer (3)

Sol. Golden rice is vitamin A enriched rice, with a gene from daffodil and is rich in carotene.

37. What is the genetic disorder in which an individual has an overall masculine development gynaecomastia, and is sterile ?

- (1) Edward syndrome
- (2) Down's syndrome
- (3) Turner's syndrome
- (4) Klinefelter's syndrome

Answer (4)

Sol. Individuals with Klinefelter's syndrome have trisomy of sex chromosome as 44 + XXY (47). They show overall masculine development, gynaecomastia and are sterile.

38. Which one of the following statements regarding post-fertilization development in flowering plants is incorrect?

- (1) Central cell develops into endosperm
- (2) Ovules develop into embryo sac
- (3) Ovary develops into fruit
- (4) Zygote develops into embryo

Answer (2)

Sol. Following are the post-fertilisation changes.

- Ovule → Seed
- Ovary → Fruit
- Zygote → Embryo
- Central cell → Endosperm

39. Which of the following is the most important cause for animals and plants being driven to extinction?
- (1) Economic exploitation
 - (2) Alien species invasion
 - (3) Habitat loss and fragmentation
 - (4) Drought and floods

Answer (3)

Sol. Habitat loss and fragmentation is the most important cause driving animals and plants to extinction.

eg: Loss of tropical rainforest reducing the forest cover from 14 % to 6 %.

40. Which of the following contraceptive methods do involve a role of hormone?
- (1) CuT, Pills, Emergency contraceptives.
 - (2) Pills, Emergency contraceptives, Barrier methods.
 - (3) Lactational amenorrhea, Pills Emergency contraceptives.
 - (4) Barrier method, Lactational amenorrhea, Pills.

Answer (3)

Sol. → In lactational amenorrhoea, due to high prolactin level, gonadotropin level decreases.

→ Oral pills are either progestogens or progestogen-estrogen combinations used by the females.

→ Emergency contraceptives includes the administration of progestogens or progestogen-estrogen combination or IUDs within 72 hour of coitus.

So, lactational amenorrhoea, oral pills and emergency contraceptives involve a role of hormone.

41. Consider following features
- (a) Organ system level of organisation
 - (b) Bilateral symmetry
 - (c) True coelomates with segmentation of body
- Select the correct option of animal groups which possess all the above characteristics
- (1) Arthropoda, Mollusca and Chordata
 - (2) Annelida, Mollusca and Chordata
 - (3) Annelida, Arthropoda and Chordata
 - (4) Annelida, Arthropoda and Mollusca

Answer (3)

Sol. True segmentation is present in Annelida, Arthropoda and Chordata. They also have organ system level of organisation, bilateral symmetry and are true coelomates

42. Which of the following factors is responsible for the formation of concentrated urine?
- (1) Secretion of erythropoietin by Juxtaglomerular complex
 - (2) Hydrostatic pressure during glomerular filtration
 - (3) Low levels of antidiuretic hormone
 - (4) Maintaining hyperosmolarity towards inner medullary interstitium in the kidneys.

Answer (4)

Sol. The proximity between loop of henle and vasa recta as well as counter current in them help in maintaining an increasing osmolality towards the inner medullary interstitium. This mechanism help to maintain a concentration gradient in medullary interstitium so human urine is nearly four times concentrated than initial filtrate formed.

43. Match the following organisms with their respective characteristics :

- | | |
|--------------------------|-------------------------|
| (a) <i>Pila</i> | (i) Flame cells |
| (b) <i>Bombyx</i> | (ii) Comb plates |
| (c) <i>Pleurobrachia</i> | (iii) Radula |
| (d) <i>Taenia</i> | (iv) Malpighian tubules |

Select the correct option from the following :

- | | | | |
|-----------|------|-------|------|
| (a) | (b) | (c) | (d) |
| (1) (ii) | (iv) | (iii) | (i) |
| (2) (iii) | (ii) | (iv) | (i) |
| (3) (iii) | (ii) | (i) | (iv) |
| (4) (iii) | (iv) | (ii) | (i) |

Answer (4)

Sol. (a) *Pila* is a Mollusc. The mouth contains a file - like rasping organ for feeding called radula.

(b) *Bombyx* is an Arthropod. In *Bombyx* excretion takes place through malpighian tubules.

(c) *Pleurobrachia* is Ctenophore. The body bears eight external rows of ciliated comb plates, which help in locomotion.

(d) *Taenia* is a platyhelminth specialised cells called flame cells helps in osmoregulation and excretion

44. Xylem translocates
- (1) Water, mineral salts and some organic nitrogen only
 - (2) Water, mineral salts, some organic nitrogen and hormones
 - (3) Water only
 - (4) Water and mineral salts only

Answer (2)

Sol. Xylem is associated with translocation of mainly water, mineral salts, some organic nitrogen and hormones.

45. What is the direction of movement of sugars in phloem?
- (1) Downward
 - (2) Bi-directional
 - (3) Non-multidirectional
 - (4) Upward

Answer (2)

Sol. The direction of movement of sugar in phloem is bi-directional as it depends on source-sink relationship which is variable in plants.

46. The correct sequence of phases of cell cycle is
- (1) $S \rightarrow G_1 \rightarrow G_2 \rightarrow M$
 - (2) $G_1 \rightarrow S \rightarrow G_2 \rightarrow M$
 - (3) $M \rightarrow G_1 \rightarrow G_2 \rightarrow S$
 - (4) $G_1 \rightarrow G_2 \rightarrow S \rightarrow M$

Answer (2)

Sol. The correct sequence of phases of cell cycle is $G_1 \rightarrow S \rightarrow G_2 \rightarrow M$

47. The shorter and longer arms of a submetacentric chromosome are referred to as
- (1) q-arm and p-arm respectively
 - (2) m-arm and n-arm respectively
 - (3) s-arm and l-arm respectively
 - (4) p-arm and q-arm respectively

Answer (4)

Sol.

- Sub metacentric chromosome is Heterobrachial.
- Short arm designated as 'p' arm (p = petite *i.e.* short)
- Long arm designated as 'q' arm

48. Which of the following can be used as a biocontrol agent in the treatment of plant disease?
- (1) *Anabaena*
 - (2) *Lactobacillus*
 - (3) *Trichoderma*
 - (4) *Chlorella*

Answer (3)

Sol. Fungus *Trichoderma* is a biological control agent being developed for use in the treatment of plant diseases.

49. Which of the following glucose transporters is insulin-dependent?
- (1) GLUT III
 - (2) GLUT IV
 - (3) GLUT I
 - (4) GLUT II

Answer (2)

Sol. GLUT-IV is insulin dependent and is responsible for majority of glucose transport into muscle and adipose cells in anabolic conditions. Whereas GLUT-I is insulin independent and is widely distributed in different tissues.

50. Purines found both in DNA and RNA are
- (1) Guanine and cytosine
 - (2) Cytosine and thymine
 - (3) Adenine and thymine
 - (4) Adenine and guanine

Answer (4)

Sol. Purines found both in DNA and RNA are Adenine and guanine

51. Drug called 'Heroin' is synthesized by
- (1) glycosylation of morphine
 - (2) nitration of morphine
 - (3) methylation of morphine
 - (4) acetylation of morphine

Answer (4)

Sol. Heroin, commonly called smack and is chemically diacetylmorphine which is synthesized by acetylation of morphine.

52. Select the correct option.
- (1) Each rib is a flat thin bone and all the ribs are connected dorsally to the thoracic vertebrae and ventrally to the sternum.
 - (2) There are seven pairs of vertebrosteral, three pairs of vertebrochondral and two pairs of vertebral ribs.
 - (3) 8th, 9th and 10th pairs of ribs articulate directly with the sternum.
 - (4) 11th and 12th pairs of ribs are connected to the sternum with the help of hyaline cartilage.

Answer (2)

- Sol.** • Vertebrosteral ribs are true ribs, dorsally they are attached to the thoracic vertebrae and ventrally connected to the sternum with the help of hyaline cartilage. First seven pairs of ribs are called true ribs.
- 8th, 9th and 10th pairs of ribs do not articulate directly with the sternum but join the seventh ribs with the help of hyaline cartilage. These are vertebrochondral or false ribs.
 - Last 2 pairs (11 & 12) of ribs are not connected ventrally and are therefore, called floating ribs.
 - Only first seven pairs of ribs are ventrally connected to the sternum.

53. A gene locus has two alleles A, a. If the frequency of dominant allele A is 0.4, then what will be the frequency of homozygous dominant, heterozygous and homozygous recessive individuals in the population?

- (1) 0.16(AA); 0.48(Aa); 0.36(aa)
- (2) 0.16(AA); 0.36(Aa); 0.48(aa)
- (3) 0.36(AA); 0.48(Aa); 0.16(aa)
- (4) 0.16(AA); 0.24(Aa); 0.36(aa)

Answer (1)

Sol. Frequency of dominant allele (say p) = 0.4

Frequency of recessive allele (say q)

$$= 1 - 0.4 = 0.6$$

∴ Frequency of homozygous dominant individuals (AA)

$$= p^2 = (0.4)^2 = 0.16$$

Frequency of heterozygous individuals (Aa)

$$= 2pq = 2(0.4)(0.6) = 0.48$$

Frequency of homozygous recessive individuals (aa)

$$= q^2 = (0.6)^2 = 0.36$$

54. Which of the following statements regarding mitochondria is incorrect?

- (1) Inner membrane is convoluted with infoldings.
- (2) Mitochondrial matrix contains single circular DNA molecule and ribosomes.
- (3) Outer membrane is permeable to monomers of carbohydrates, fats and proteins.
- (4) Enzymes of electron transport are embedded in outer membrane.

Answer (4)

Sol. In mitochondria, enzymes for electron transport are present in the inner membrane.

55. Variations caused by mutation, as proposed by Hugo de Vries are

- (1) small and directional
- (2) small and directionless
- (3) random and directional
- (4) random and directionless

Answer (4)

Sol. According to Hugo de Vries, mutations are random and directionless.

Devries believed mutation caused speciation and hence called saltation (single step large mutation).

56. Following statements describe the characteristics of the enzyme Restriction Endonuclease. Identify the incorrect statement.

- (1) The enzyme cuts the sugar-phosphate backbone at specific sites on each strand.
- (2) The enzyme recognizes a specific palindromic nucleotide sequence in the DNA.
- (3) The enzyme cuts DNA molecule at identified position within the DNA.
- (4) The enzyme binds DNA at specific sites and cuts only one of the two strands.

Answer (4)

Sol. Restriction enzymes cut DNA molecules at a particular point by recognising a specific sequence. Each restriction endonuclease functions by inspecting the length of a DNA sequence. Once it finds its specific recognition sequence, it will bind to the DNA and cut each of the two strands of the double helix at specific points in their sugar-phosphate backbone.

57. Which part of the brain is responsible for thermoregulation?

- (1) Corpus callosum
- (2) Medulla oblongata
- (3) Cerebrum
- (4) Hypothalamus

Answer (4)

Sol. Hypothalamus in the thermoregulatory centre of our brain. It is responsible for maintaining constant body temperature.

58. Use of an artificial kidney during hemodialysis may result in :
- Nitrogenous waste build-up in the body
 - Non-elimination of excess potassium ions
 - Reduced absorption of calcium ions from gastro-intestinal tract
 - Reduced RBC production

Which of the following options is the most appropriate?

- (c) and (d) are correct
- (a) and (d) are correct
- (a) and (b) are correct
- (b) and (c) are correct

Answer (1)

Sol. (a) and (b) statements are incorrect because dialysis eliminates urea and potassium from the body whereas, c and d are correct. As phosphate ions are eliminated during dialysis, along with that calcium ions are also eliminated. So, there will be reduced absorption of calcium ions from gastrointestinal tract. RBC production will be reduced, due to reduced erythropoietin hormone.

59. What triggers activation of protoxin to active Bt toxin of *Bacillus thuringiensis* in boll worm?
- Alkaline pH of gut
 - Acidic pH of stomach
 - Body temperature
 - Moist surface of midgut

Answer (1)

Sol. *Bacillus thuringiensis* forms protein crystals during a particular phase of their growth. These crystals contain a toxic insecticidal protein. These protein exist as inactive protoxins but once an insect ingest the inactive toxin, it is converted into an active form of toxin due to alkaline pH of the gut which solubilize the crystals. The activated toxin binds to the surface of midgut epithelial cells and create pores that cause cell swelling and lysis and eventually cause death of insect.

60. Which of the following protocols did aim for reducing emission of chlorofluorocarbons into the atmosphere?
- Gothenburg Protocol
 - Geneva Protocol
 - Montreal Protocol
 - Kyoto Protocol

Answer (3)

Sol. To control the deleterious effect of the stratospheric ozone depletion an international treaty was signed at Montreal, Canada in 1987. It is popularly known as Montreal protocol.

61. Which of the following sexually transmitted diseases is not completely curable?
- Genital herpes
 - Chlamydia
 - Gonorrhoea
 - Genital warts

Answer (1)

Sol. Genital herpes is caused by type-II-herpes simplex virus. At present there is no cure for type-II-herpes simplex virus and therefore the disease caused, genital herpes. Other non-curable STIs are hepatitis-B and HIV.

62. *Thiobacillus* is a group of bacteria helpful in carrying out
- Nitrification
 - Denitrification
 - Nitrogen fixation
 - Chemoautotrophic fixation

Answer (2)

Sol. *Thiobacillus denitrificans* cause denitrification *i.e.*, conversion of oxides of nitrogen to free N_2 .

63. In *Antirrhinum* (Snapdragon), a red flower was crossed with a white flower and in F_1 generation pink flowers were obtained. When pink flowers were selfed, the F_2 generation showed white, red and pink flowers. Choose the incorrect statement from the following :

- Ratio of F_2 is $\frac{1}{4}$ (Red) : $\frac{2}{4}$ (Pink) : $\frac{1}{4}$ (White)
- Law of Segregation does not apply in this experiment
- This experiment does not follow the Principle of Dominance.
- Pink colour in F_1 is due to incomplete dominance.

Answer (2)

Sol. Genes for flower colour in snapdragon shows incomplete dominance which is an exception of Mendel's first principle *i.e.* Law of dominance.

Whereas Law of segregation is universally applicable.

64. In a species, the weight of newborn ranges from 2 to 5 kg. 97% of the newborn with an average weight between 3 to 3.3 kg survive whereas 99% of the infants born with weights from 2 to 2.5 kg or 4.5 to 5 kg die. Which type of selection process is taking place?
- (1) Disruptive Selection
 - (2) Cyclical Selection
 - (3) Directional Selection
 - (4) Stabilizing Selection

Answer (4)

Sol. The given data shows stabilising selection as most of the newborn having average weight between 3 to 3.3 kg survive and babies with less and more weight have low survival rate.

65. Concanavalin A is
- (1) a lectin
 - (2) a pigment
 - (3) an alkaloid
 - (4) an essential oil

Answer (1)

Sol. Concanavalin A is a secondary metabolite *e.g* is lectin, it has the property to agglutinates RBCs.

66. Match the Column-I with Column-II

| Column-I | Column-II |
|-------------------------------------|-----------------------------------|
| (a) P - wave | (i) Depolarisation of ventricles |
| (b) QRS complex | (ii) Repolarisation of ventricles |
| (c) T - wave | (iii) Coronary ischemia |
| (d) Reduction in the size of T-wave | (iv) Depolarisation of atria |
| | (v) Repolarisation of atria |

Select the correct option.

- | | (a) | (b) | (c) | (d) |
|-----|------|-------|------|-------|
| (1) | (ii) | (i) | (v) | (iii) |
| (2) | (ii) | (iii) | (v) | (iv) |
| (3) | (iv) | (i) | (ii) | (iii) |
| (4) | (iv) | (i) | (ii) | (v) |

Answer (3)

Sol. In ECG P-wave represents depolarisation of atria. QRS complex represents depolarisation of ventricles. T-wave represents repolarisation of ventricle *i.e.* return from excited to normal state. Reduction in the size of T-wave *i.e.* if the T-wave represents insufficient supply of oxygen *i.e.* coronary ischaemia.

67. Match the following genes of the Lac operon with their respective products :

- | | |
|------------|----------------------------|
| (a) i gene | (i) β -galactosidase |
| (b) z gene | (ii) Permease |
| (c) a gene | (iii) Repressor |
| (d) y gene | (iv) Transacetylase |

Select the correct option.

- | | (a) | (b) | (c) | (d) |
|-----|-------|-------|------|------|
| (1) | (iii) | (i) | (iv) | (ii) |
| (2) | (iii) | (iv) | (i) | (ii) |
| (3) | (i) | (iii) | (ii) | (iv) |
| (4) | (iii) | (i) | (ii) | (iv) |

Answer (1)

Sol. In lac operon

- i gene — Repressor
z gene — β -galactosidase
y gene — Permease
a gene — Transacetylase

68. Which of the following statements is not correct?

- (1) Lysosomes are membrane bound structures
- (2) Lysosomes are formed by the process of packaging in the endoplasmic reticulum
- (3) Lysosomes have numerous hydrolytic enzymes
- (4) The hydrolytic enzymes of lysosomes are active under acidic pH

Answer (2)

Sol. Lysosomes bud off from trans face of Golgi bodies.

Precursor of lysosomal enzymes are synthesised by RER and then send to Golgi bodies for further processing.

69. In some plants, the female gamete develops into embryo without fertilization. This phenomenon is known as

- (1) Syngamy
- (2) Parthenogenesis
- (3) Autogamy
- (4) Parthenocarp

Answer (2)

Sol. The phenomenon in which female gamete develops into embryo without getting fused with male gamete (fertilisation) is called parthenogenesis.

70. Match Column - I with Column - II
- | Column - I | Column - II |
|----------------|-----------------------------------------------------|
| (a) Saprophyte | (i) Symbiotic association of fungi with plant roots |
| (b) Parasite | (ii) Decomposition of dead organic materials |
| (c) Lichens | (iii) Living on living plants or animals |
| (d) Mycorrhiza | (iv) Symbiotic association of algae and fungi |

Choose the correct answer from the options given below

- | | (a) | (b) | (c) | (d) |
|-----|-------|-------|-------|------|
| (1) | (ii) | (i) | (iii) | (iv) |
| (2) | (ii) | (iii) | (iv) | (i) |
| (3) | (i) | (ii) | (iii) | (iv) |
| (4) | (iii) | (ii) | (i) | (iv) |

Answer (2)

- Sol.** Saprophytes - Decomposition of dead organic materials
 Parasites - Grow on/in living plants and animals
 Lichens - Symbiotic association algae and fungi
 Mycorrhiza - Symbiotic association of fungi with plant roots

71. Which of the following is a commercial blood cholesterol lowering agent?
- (1) Streptokinase (2) Lipases
 (3) Cyclosporin A (4) Statin

Answer (4)

- Sol.** • Statin is obtained from a yeast (Fungi) called *Monascus purpureus*
 • It acts by competitively inhibiting the enzyme responsible for synthesis of cholesterol.

72. Which of the following features of genetic code does allow bacteria to produce human insulin by recombinant DNA technology?
- (1) Genetic code is nearly universal
 (2) Genetic code is specific
 (3) Genetic code is not ambiguous
 (4) Genetic code is redundant

Answer (1)

- Sol.** In recombinant DNA technology bacteria is able to produce human insulin because genetic code is nearly universal.

73. The ciliated epithelial cells are required to move particles or mucus in a specific direction. In humans, these cells are mainly present in
- (1) Eustachian tube and Salivary duct
 (2) Bronchioles and Fallopian tubes
 (3) Bile duct and Bronchioles
 (4) Fallopian tubes and Pancreatic duct

Answer (2)

- Sol.** Bronchioles and Fallopian tubes are lined with ciliated epithelium to move particles or mucus in a specific direction.

74. Conversion of glucose to glucose-6-phosphate, the first irreversible reaction of glycolysis, is catalyzed by
- (1) Enolase
 (2) Phosphofructokinase
 (3) Aldolase
 (4) Hexokinase

Answer (4)

- Sol.** Hexokinase catalyse the conversion of Glucose to Glucose-6 phosphate. It is the first step of activation phase of glycolysis.

75. Which one of the following is not a method of *in situ* conservation of biodiversity?
- (1) Botanical Garden (2) Sacred Grove
 (3) Biosphere Reserve (4) Wildlife Sanctuary

Answer (1)

- Sol.** Botanical garden - ex - situ conservation (off-site conservation) i.e. living plants (flora) are conserved in human managed system.

76. The concept of "*Omnis cellula-e cellula*" regarding cell division was first proposed by
- (1) Schleiden
 (2) Aristotle
 (3) Rudolf Virchow
 (4) Theodor Schwann

Answer (3)

- Sol.** Concept of "*Omnis cellula-e cellula*" regarding cell division was proposed by Rudolf Virchow.

77. Select the correct group of biocontrol agents.
- (1) *Oscillatoria*, *Rhizobium*, *Trichoderma*
 (2) *Nostoc*, *Azospirillum*, *Nucleopolyhedrovirus*
 (3) *Bacillus thuringiensis*, Tobacco mosaic virus, Aphids
 (4) *Trichoderma*, *Baculovirus*, *Bacillus thuringiensis*

Answer (4)

Sol. Fungi *Trichoderma*, Baculoviruses (NPV) and *Bacillus thuringiensis* are used as biocontrol agents.

Rhizobium, *Nostoc*, *Azospirillum* and *Oscillatoria* are used as biofertilisers, whereas TMV is a pathogen and aphids are pests that harm crop plants.

78. Identify the correct pair representing the causative agent of typhoid fever and the confirmatory test for typhoid.

- (1) *Salmonella typhi* / Anthrone test
- (2) *Salmonella typhi* / Widal test
- (3) *Plasmodium vivax* / UTI test
- (4) *Streptococcus pneumoniae* / Widal test

Answer (2)

Sol. *Salmonella typhi* is the causative agent. Confirmatory test = Widal test, it's based on antigen antibody reaction.

79. Select the incorrect statement.

- (1) In domesticated fowls, sex of progeny depends on the type of sperm rather than egg
- (2) Human males have one of their sex-chromosome much shorter than the other
- (3) Male fruit fly is heterogametic
- (4) In male grasshoppers 50% of sperms have no sex-chromosome

Answer (1)

Sol. In birds female heterogamety is found thus sex of progeny depends on the types of egg rather than the type of sperm.

eg.

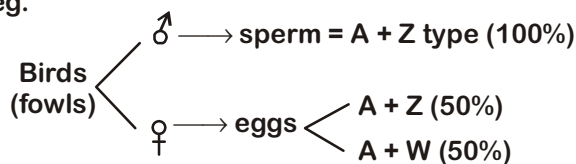

80. Select the correct sequence of organs in the alimentary canal of cockroach starting from mouth

- (1) Pharynx → Oesophagus → Gizzard → Ileum → Crop → Colon → Rectum
- (2) Pharynx → Oesophagus → Ileum → Crop → Gizzard → Colon → Rectum
- (3) Pharynx → Oesophagus → Crop → Gizzard → Ileum → Colon → Rectum
- (4) Pharynx → Oesophagus → Gizzard → Crop → Ileum → Colon → Rectum

Answer (3)

Sol. The correct sequence of organs in the alimentary canal of cockroach starting from mouth is :

Pharynx → Oesophagus → Crop → Gizzard → Ileum → Colon → Rectum

81. Colostrum the yellowish fluid, secreted by mother during the initial days of lactation is very essential to impart immunity to the new born infants because it contains

- (1) Macrophages
- (2) Immunoglobulin A
- (3) Natural killer cells
- (4) Monocytes

Answer (2)

Sol. Colostrum, the yellowish fluid secreted by the mother during initial days of lactation is very essential to impart immunity to the new born infant because it contains Immunoglobulin A. It will impart naturally acquired passive immunity to the newborn

82. What is the fate of the male gametes discharged in the synergid?

- (1) One fuses with the egg, other(s) fuse(s) with synergid nucleus.
- (2) One fuses with the egg and other fuses with central cell nuclei.
- (3) One fuses with egg other(s) degenerate(s) in the synergid.
- (4) All fuse with the egg.

Answer (2)

Sol. In flowering plants, out of the two male gametes discharged in synergids, one fuses with the egg and other fuses with the secondary or definitive nucleus present in central cell.

Egg (n) + 1st male gamete (n) → Zygote (2n)

Secondary nucleus + 2nd male gamete (n) →

(2n)
(central cell nuclei)

PEN (3n)

83. What map unit (Centimorgan) is adopted in the construction of genetic maps?

- (1) A unit of distance between genes on chromosomes, representing 1% cross over.
- (2) A unit of distance between genes on chromosomes, representing 50% cross over.
- (3) A unit of distance between two expressed genes representing 10% cross over.
- (4) A unit of distance between two expressed genes representing 100% cross over.

Answer (1)

Sol. 1 map unit represent 1 % cross over.
Map unit is used to measure genetic distance.
This genetic distance is based on average number of cross over frequency.

84. Select the hormone-releasing Intra-Uterine Devices.

- (1) Progestasert, LNG-20
- (2) Lippes Loop, Multiload 375
- (3) Vaults, LNG-20
- (4) Multiload 375, Progestasert

Answer (1)

Sol. Progestasert and LNG-20 are hormone releasing IUDs which make the uterus unsuitable for implantation and the cervix hostile to sperms.

85. Select the correctly written scientific name of Mango which was first described by Carolus Linnaeus

- (1) *Mangifera indica*
- (2) *Mangifera Indica*
- (3) *Mangifera indica* Car. Linn.
- (4) *Mangifera indica* Linn.

Answer (4)

Sol. According to rules of binomial nomenclature, correctly written scientific name of mango is *Mangifera indica* Linn.

86. Which of the following pairs of gases is mainly responsible for green house effect?

- (1) Nitrogen and Sulphur dioxide
- (2) Carbon dioxide and Methane
- (3) Ozone and Ammonia
- (4) Oxygen and Nitrogen

Answer (2)

Sol. Relative contribution of various greenhouse gases to total global warming is

- $\text{CO}_2 = 60\%$
- $\text{CH}_4 = 20\%$
- CFC = 14%
- $\text{N}_2\text{O} = 6\%$

⇒ Therefore CO_2 and CH_4 are the major greenhouse gases

87. The frequency of recombination between gene pairs on the same chromosome as a measure of the distance between genes was explained by :

- (1) Alfred Sturtevant
- (2) Sutton Boveri
- (3) T.H. Morgan
- (4) Gregor J. Mendel

Answer (1)

Sol. Alfred Sturtevant explained chromosomal mapping on the basis of recombination frequency which is directly proportional to distance between two genes on same chromosome

88. Which of the following statements is correct?

- (1) Cornea is convex, transparent layer which is highly vascularised.
- (2) Cornea consists of dense matrix of collagen and is the most sensitive portion the eye.
- (3) Cornea is an external, transparent and protective proteinacious covering of the eye-ball.
- (4) Cornea consists of dense connective tissue of elastin and can repair itself.

Answer (2)

Sol. Cornea consists of dense matrix of collagen and corneal epithelium. It is the most sensitive part of eye.

89. Which of the following muscular disorders is inherited?

- (1) Myasthenia gravis
- (2) Botulism
- (3) Tetany
- (4) Muscular dystrophy

Answer (4)

Sol. Progressive degeneration of skeletal muscle mostly due to genetic disorder is muscular dystrophy where as tetany is muscular spasm due to low calcium in body fluid. Myasthenia gravis is an auto immune disorder leading to paralysis of skeletal muscles. Botulism is rare and dangerous type of food poisoning caused by bacterium *Clostridium Botulinum*.

90. Polyblend, a fine powder of recycled modified plastic, has proved to be a good material for

- (1) Construction of roads
- (2) Making tubes and pipes
- (3) Making plastic sacks
- (4) Use as a fertilizer

Answer (1)

Sol. Polyblend is a fine powder of recycled modified plastic waste. The mixture is mixed with bitumen that is used to lay roads.

91. Average velocity of a particle executing SHM in one complete vibration is :

- (1) $\frac{A\omega^2}{2}$ (2) Zero
 (3) $\frac{A\omega}{2}$ (4) $A\omega$

Answer (2)

Sol. In one complete vibration, displacement is zero. So, average velocity in one complete vibration

$$= \frac{\text{Displacement}}{\text{Time interval}} = \frac{y_f - y_i}{T} = 0$$

92. Two similar thin equi-convex lenses, of focal length f each, are kept coaxially in contact with each other such that the focal length of the combination is F_1 . When the space between the two lenses is filled with glycerine (which has the same refractive index ($\mu = 1.5$) as that of glass) then the equivalent focal length is F_2 . The ratio $F_1 : F_2$ will be :

- (1) 2 : 3 (2) 3 : 4
 (3) 2 : 1 (4) 1 : 2

Answer (4)

Sol.

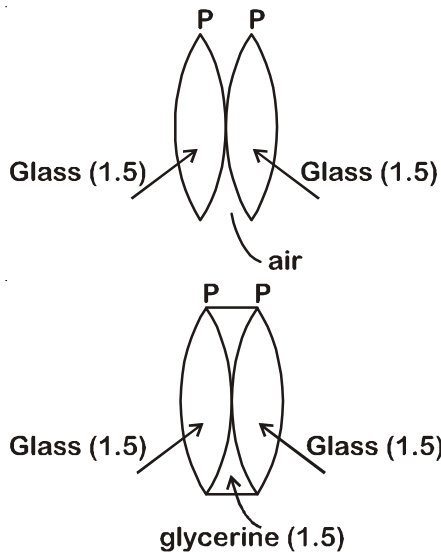

Equivalent focal length in air $\frac{1}{F_1} = \frac{1}{f} + \frac{1}{f} = \frac{2}{f}$

When glycerin is filled inside, glycerin lens behaves like a diverging lens of focal length $(-f)$

$$\frac{1}{F_2} = \frac{1}{f} + \frac{1}{f} - \frac{1}{f}$$

$$= \frac{1}{f}$$

$$\frac{F_1}{F_2} = \frac{1}{2}$$

93. A particle moving with velocity \vec{v} is acted by three forces shown by the vector triangle PQR. The velocity of the particle will :

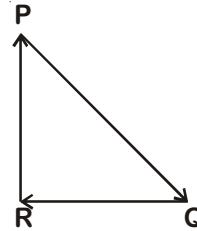

- (1) Remain constant
 (2) Change according to the smallest force

\vec{QR}

- (3) Increase
 (4) Decrease

Answer (1)

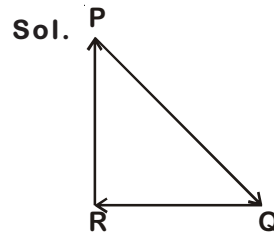

As forces are forming closed loop in same order

So, $\vec{F}_{net} = 0$

$$\Rightarrow m \frac{d\vec{v}}{dt} = 0$$

$$\Rightarrow \vec{v} = \text{constant}$$

94. Ionized hydrogen atoms and α -particles with same momenta enters perpendicular to a constant magnetic field, B. The ratio of their radii of their paths $r_H : r_\alpha$ will be :

- (1) 4 : 1 (2) 1 : 4
 (3) 2 : 1 (4) 1 : 2

Answer (3)

Sol. $r_H = \frac{p}{eB}$

$$r_\alpha = \frac{p}{2eB}$$

$$\frac{r_H}{r_\alpha} = \frac{eB}{2eB}$$

$$\frac{r_H}{r_\alpha} = \frac{2}{1}$$

95. Body A of mass $4m$ moving with speed u collides with another body B of mass $2m$, at rest. The collision is head on and elastic in nature. After the collision the fraction of energy lost by the colliding body A is :

- (1) $\frac{4}{9}$ (2) $\frac{5}{9}$
 (3) $\frac{1}{9}$ (4) $\frac{8}{9}$

Answer (4)

Sol. Fractional loss of KE of colliding body

$$\frac{\Delta KE}{KE} = \frac{4(m_1 m_2)}{(m_1 + m_2)^2}$$

$$= \frac{4(4m)2m}{(4m + 2m)^2}$$

$$= \frac{32m^2}{36m^2} = \frac{8}{9}$$

96. The speed of a swimmer in still water is 20 m/s . The speed of river water is 10 m/s and is flowing due east. If he is standing on the south bank and wishes to cross the river along the shortest path the angle at which he should make his strokes w.r.t. north is given by :

- (1) 60° west (2) 45° west
 (3) 30° west (4) 0°

Answer (3)

Sol. $V_{SR} = 20 \text{ m/s}$
 $V_{RG} = 10 \text{ m/s}$

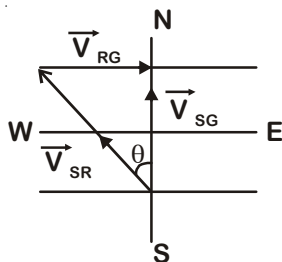

$$\vec{V}_{SG} = \vec{V}_{SR} + \vec{V}_{RG}$$

$$\sin\theta = \frac{|\vec{V}_{RG}|}{|\vec{V}_{SR}|}$$

$$\sin\theta = \frac{10}{20}$$

$$\sin\theta = \frac{1}{2}$$

$\theta = 30^\circ$ west

97. In the circuits shown below, the readings of voltmeters and the ammeters will be

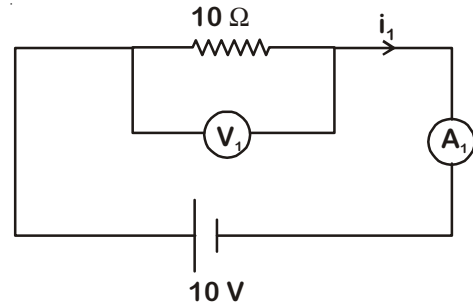

Circuit 1

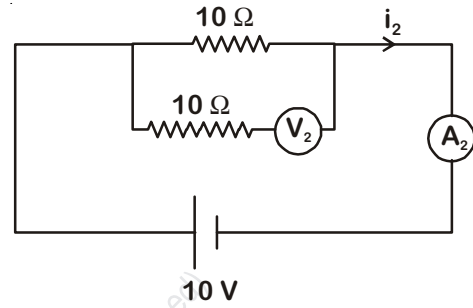

Circuit 2

- (1) $V_1 = V_2$ and $i_1 = i_2$ (2) $V_2 > V_1$ and $i_1 > i_2$
 (3) $V_2 > V_1$ and $i_1 = i_2$ (4) $V_1 = V_2$ and $i_1 > i_2$

Answer (1)

Sol. For ideal voltmeter, resistance is infinite and for the ideal ammeter, resistance is zero.

$$V_1 = i_1 \times 10 = \frac{10}{10} \times 10 = 10 \text{ volt}$$

$$V_2 = i_2 \times 10 = \frac{10}{10} \times 10 = 10 \text{ volt}$$

$$V_1 = V_2$$

$$i_1 = i_2 = \frac{10 \text{ V}}{10 \Omega} = 1 \text{ A}$$

98. A 800 turn coil of effective area 0.05 m^2 is kept perpendicular to a magnetic field $5 \times 10^{-5} \text{ T}$. When the plane of the coil is rotated by 90° around any of its coplanar axis in 0.1 s , the emf induced in the coil will be:

- (1) $2 \times 10^{-3} \text{ V}$ (2) 0.02 V
 (3) 2 V (4) 0.2 V

Answer (2)

Sol. Magnetic field $B = 5 \times 10^{-5} \text{ T}$

Number of turns in coil $N = 800$

Area of coil $A = 0.05 \text{ m}^2$

Time taken to rotate $\Delta t = 0.1 \text{ s}$

Initial angle $\theta_1 = 0^\circ$

Final angle $\theta_2 = 90^\circ$

Change in magnetic flux $\Delta\phi$

$$= NBA\cos 90^\circ - BA\cos 0^\circ$$

$$= -NBA$$

$$= -800 \times 5 \times 10^{-5} \times 0.05$$

$$= -2 \times 10^{-3} \text{ weber}$$

$$e = -\frac{\Delta\phi}{\Delta t} = \frac{-(-)2 \times 10^{-3} \text{ Wb}}{0.1 \text{ s}} = 0.02 \text{ V}$$

99. At a point A on the earth's surface the angle of dip, $\delta = +25^\circ$. At a point B on the earth's surface the angle of dip, $\delta = -25^\circ$. We can interpret that:

- (1) A is located in the northern hemisphere and B is located in the southern hemisphere.
- (2) A and B are both located in the southern hemisphere.
- (3) A and B are both located in the northern hemisphere.
- (4) A is located in the southern hemisphere and B is located in the northern hemisphere.

Answer (1)

Sol. Angle of dip is the angle between earth's resultant magnetic field from horizontal. Dip is zero at equator and positive in northern hemisphere.

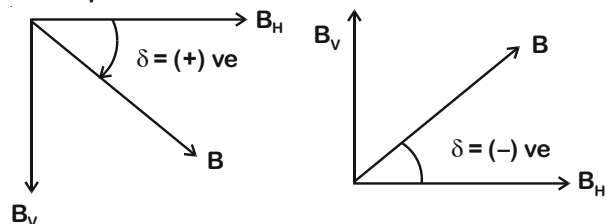

In southern hemisphere dip angle is considered as negative.

100. An electron is accelerated through a potential difference of 10,000 V. Its de Broglie wavelength is, (nearly) : ($m_e = 9 \times 10^{-31} \text{ kg}$)

- (1) $12.2 \times 10^{-14} \text{ m}$
- (2) 12.2 nm
- (3) $12.2 \times 10^{-13} \text{ m}$
- (4) $12.2 \times 10^{-12} \text{ m}$

Answer (4)

Sol. For an electron accelerated through a potential V

$$\lambda = \frac{12.27}{\sqrt{V}} \text{ \AA} = \frac{12.27 \times 10^{-10}}{\sqrt{10000}} = 12.27 \times 10^{-12} \text{ m}$$

101. The displacement of a particle executing simple harmonic motion is given by

$$y = A_0 + A\sin\omega t + B\cos\omega t$$

Then the amplitude of its oscillation is given by :

$$(1) \sqrt{A_0^2 + (A+B)^2}$$

$$(2) A + B$$

$$(3) A_0 + \sqrt{A^2 + B^2}$$

$$(4) \sqrt{A^2 + B^2}$$

Answer (4)

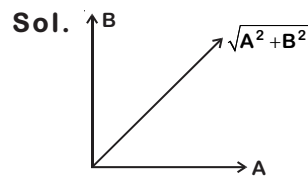

$$y = A_0 + A\sin\omega t + B\sin\omega t$$

Equate SHM

$$y' = y - A_0 = A\sin\omega t + B\cos\omega t$$

Resultant amplitude

$$R = \sqrt{A^2 + B^2 + 2AB\cos 90^\circ}$$

$$= \sqrt{A^2 + B^2}$$

102. α -particle consists of :

- (1) 2 electrons and 4 protons only
- (2) 2 protons only
- (3) 2 protons and 2 neutrons only
- (4) 2 electrons, 2 protons and 2 neutrons

Answer (3)

Sol. α -particle is nucleus of Helium which has two protons and two neutrons.

103. A hollow metal sphere of radius R is uniformly charged. The electric field due to the sphere at a distance r from the centre

- (1) Zero as r increases for $r < R$, increases as r increases for $r > R$
- (2) Decreases as r increases for $r < R$ and for $r > R$
- (3) Increases as r increases for $r < R$ and for $r > R$
- (4) Zero as r increases for $r < R$, decreases as r increases for $r > R$

Answer (4)

Sol.

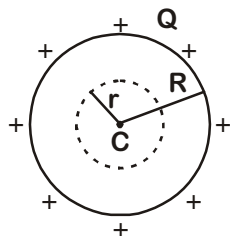

Charge Q will be distributed over the surface of hollow metal sphere.

(i) For $r < R$ (inside)

$$\oint \vec{E}_{in} \cdot d\vec{S} = \frac{q_{en}}{\epsilon_0} = 0$$

$$\Rightarrow E_{in} = 0 \quad (\because q_{en} = 0)$$

(ii) For $r > R$ (outside)

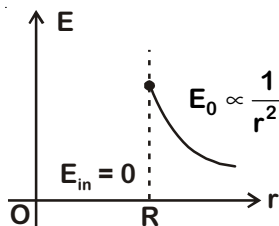
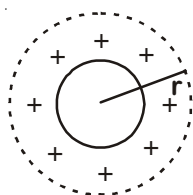

$$\oint \vec{E}_0 \cdot d\vec{S} = \frac{q_{en}}{\epsilon_0}$$

$$\text{Here, } q_{en} = Q \quad (\because q_{en} = Q)$$

$$\therefore E_0 4\pi r^2 = \frac{Q}{\epsilon_0}$$

$$\therefore E_0 \propto \frac{1}{r^2}$$

104. In an experiment, the percentage of error occurred in the measurement of physical quantities A, B, C and D are 1%, 2%, 3% and 4% respectively. Then the maximum percentage of

error in the measurement X , where $X = \frac{A^2 B^{1/2}}{C^{1/3} D^3}$,

will be

(1) - 10% (2) 10%

(3) $\left(\frac{3}{13}\right)\%$ (4) 16%

Answer (4)

Sol. Given

$$x = \frac{A^2 B^{1/2}}{C^{1/3} D^3}$$

$$\% \text{ error, } \frac{\Delta x}{x} \times 100 = 2 \frac{\Delta A}{A} \times 100 + \frac{1}{2} \frac{\Delta B}{B} \times$$

$$100 + \frac{1}{3} \frac{\Delta C}{C} \times 100 + 3 \frac{\Delta D}{D} \times 100$$

$$= 2 \times 1\% + \frac{1}{2} \times 2\% + \frac{1}{3} \times 3\% + 3 \times 4\%$$

$$= 2\% + 1\% + 1\% + 12\%$$

$$= 16\%$$

105. A force $F = 20 + 10y$ acts on a particle in y -direction where F is in newton and y in meter. Work done by this force to move the particle from $y = 0$ to $y = 1$ m is

(1) 25 J (2) 20 J

(3) 30 J (4) 5 J

Answer (1)

Sol. Work done by variable force is

$$W = \int_{y_i}^{y_f} F dy$$

$$\text{Here, } y_i = 0, y_f = 1 \text{ m}$$

$$\therefore W = \int_0^1 (20 + 10y) dy = \left[20y + \frac{10y^2}{2} \right]_0^1 = 25 \text{ J}$$

106. In which of the following processes, heat is neither absorbed nor released by a system?

(1) Isobaric (2) Isochoric

(3) Isothermal (4) Adiabatic

Answer (4)

Sol. In adiabatic process, there is no exchange of heat.

107. In which of the following devices, the eddy current effect is not used?

(1) Electromagnet

(2) Electric heater

(3) Induction furnace

(4) Magnetic braking in train

Answer (2)

Sol. Electric heater does not involve Eddy currents. It uses Joule's heating effect.

108. The unit of thermal conductivity is :

- (1) $W m K^{-1}$ (2) $W m^{-1} K^{-1}$
 (3) $J m K^{-1}$ (4) $J m^{-1} K^{-1}$

Answer (2)

Sol. The heat current related to difference of temperature across the length l of a conductor of area A is

$$\frac{dH}{dt} = \frac{KA}{l} \Delta T \quad (K = \text{coefficient of thermal conductivity})$$

$$\therefore K = \frac{l dH}{A dt \Delta T}$$

Unit of $K = Wm^{-1} K^{-1}$

109. A body weighs 200 N on the surface of the earth. How much will it weigh half way down to the centre of the earth ?

- (1) 250 N (2) 100 N
 (3) 150 N (4) 200 N

Answer (2)

Sol.

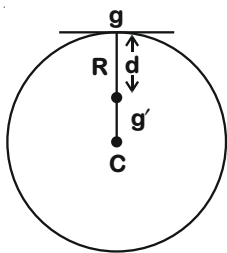

Acceleration due to gravity at a depth d from surface of earth

$$g' = g \left(1 - \frac{d}{R} \right) \quad \dots(1)$$

Where g = acceleration due to gravity at earth's surface

Multiplying by mass ' m ' on both sides of (1)

$$mg' = mg \left(1 - \frac{d}{R} \right) \quad \left(d = \frac{R}{2} \right)$$

$$= 200 \left(1 - \frac{R}{2R} \right) = \frac{200}{2} = 100 N$$

110. Two parallel infinite line charges with linear charge densities $+\lambda$ C/m and $-\lambda$ C/m are placed at a distance of $2R$ in free space. What is the electric field mid-way between the two line charges?

- (1) $\frac{\lambda}{\pi\epsilon_0 R} N/C$ (2) $\frac{\lambda}{2\pi\epsilon_0 R} N/C$
 (3) Zero (4) $\frac{2\lambda}{\pi\epsilon_0 R} N/C$

Answer (1)

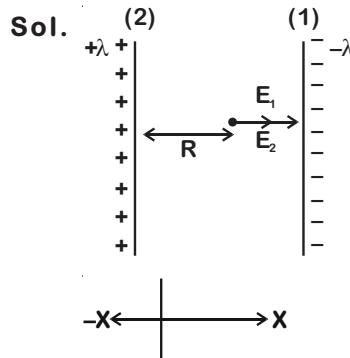

Electric field due to line charge (1)

$$\vec{E}_1 = \frac{\lambda}{2\pi\epsilon_0 R} \hat{i} N/C$$

Electric field due to line charge (2)

$$\vec{E}_2 = \frac{\lambda}{2\pi\epsilon_0 R} \hat{i} N/C$$

$$\vec{E}_{net} = \vec{E}_1 + \vec{E}_2$$

$$= \frac{\lambda}{2\pi\epsilon_0 R} \hat{i} + \frac{\lambda}{2\pi\epsilon_0 R} \hat{i}$$

$$= \frac{\lambda}{\pi\epsilon_0 R} \hat{i} N/C$$

111. A mass m is attached to a thin wire and whirled in a vertical circle. The wire is most likely to break when:

- (1) the mass is at the lowest point
 (2) inclined at an angle of 60° from vertical
 (3) the mass is at the highest point
 (4) the wire is horizontal

Answer (1)

Sol.

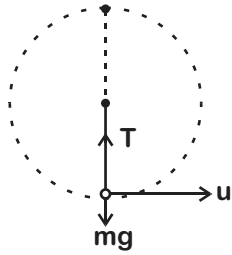

$$T - mg = \frac{mu^2}{l}$$

$$T = mg + \frac{mu^2}{l}$$

The tension is maximum at the lowest position of mass, so the chance of breaking is maximum.

112.

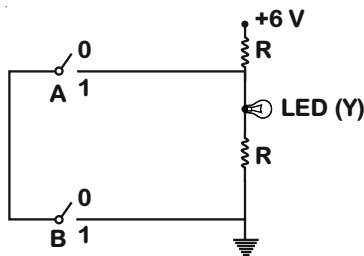

The correct Boolean operation represented by the circuit diagram drawn is :

- (1) NAND
- (2) NOR
- (3) AND
- (4) OR

Answer (1)

Sol. From the given logic circuit LED will glow, when voltage across LED is high.

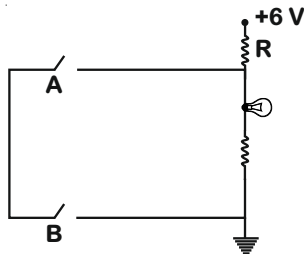

Truth Table

| A | B | Y |
|---|---|---|
| 0 | 0 | 1 |
| 0 | 1 | 1 |
| 1 | 0 | 1 |
| 1 | 1 | 0 |

This is out put of NAND gate.

113. A block of mass 10 kg is in contact against the inner wall of a hollow cylindrical drum of radius 1 m. The coefficient of friction between the block and the inner wall of the cylinder is 0.1. The minimum angular velocity needed for the cylinder to keep the block stationary when the cylinder is vertical and rotating about its axis, will be : ($g = 10 \text{ m/s}^2$)

- (1) 10 rad/s
- (2) 10π rad/s
- (3) $\sqrt{10}$ rad/s
- (4) $\frac{10}{2\pi}$ rad/s

Answer (1)

Sol.

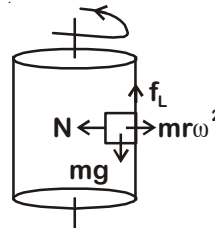

For equilibrium of the block limiting friction

$$f_L \geq mg$$

$$\Rightarrow \mu N \geq mg$$

$$\Rightarrow \mu mr\omega^2 \geq mg$$

$$\omega \geq \sqrt{\frac{g}{r\mu}}$$

$$\omega_{\min} = \sqrt{\frac{g}{r\mu}}$$

$$\omega_{\min} = \sqrt{\frac{10}{0.1 \times 1}} = 10 \text{ rad/s}$$

114. A small hole of area of cross-section 2 mm^2 is present near the bottom of a fully filled open tank of height 2 m. Taking $g = 10 \text{ m/s}^2$, the rate of flow of water through the open hole would be nearly

- (1) $2.23 \times 10^{-6} \text{ m}^3/\text{s}$
- (2) $6.4 \times 10^{-6} \text{ m}^3/\text{s}$
- (3) $12.6 \times 10^{-6} \text{ m}^3/\text{s}$
- (4) $8.9 \times 10^{-6} \text{ m}^3/\text{s}$

Answer (3)

Sol.

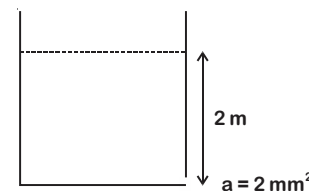

Rate of flow liquid

$$\begin{aligned}
 Q &= au = a\sqrt{2gh} \\
 &= 2 \times 10^{-6} \text{ m}^2 \times \sqrt{2 \times 10 \times 2} \text{ m/s} \\
 &= 2 \times 2 \times 3.14 \times 10^{-6} \text{ m}^3/\text{s} \\
 &= 12.56 \times 10^{-6} \text{ m}^3/\text{s} \\
 &= 12.6 \times 10^{-6} \text{ m}^3/\text{s}
 \end{aligned}$$

115. When an object is shot from the bottom of a long smooth inclined plane kept at an angle 60° with horizontal, it can travel a distance x_1 along the plane. But when the inclination is decreased to 30° and the same object is shot with the same velocity, it can travel x_2 distance. Then $x_1 : x_2$ will be:

- (1) $1:\sqrt{3}$ (2) $1:2\sqrt{3}$
 (3) $1:\sqrt{2}$ (4) $\sqrt{2}:1$

Answer (1)
 Sol.

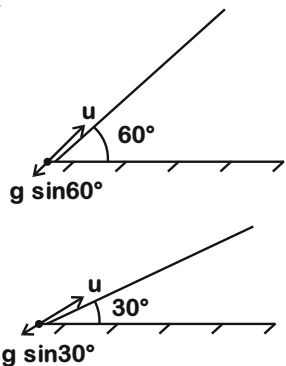

(Stopping distance) $x_1 = \frac{u^2}{2g \sin 60^\circ}$

(Stopping distance) $x_2 = \frac{u^2}{2g \sin 30^\circ}$

$$\Rightarrow \frac{x_1}{x_2} = \frac{\sin 30^\circ}{\sin 60^\circ} = \frac{1 \times 2}{2 \times \sqrt{3}} = 1:\sqrt{3}$$

116. A cylindrical conductor of radius R is carrying a constant current. The plot of the magnitude of the magnetic field, B with the distance d from the centre of the conductor, is correctly represented by the figure :

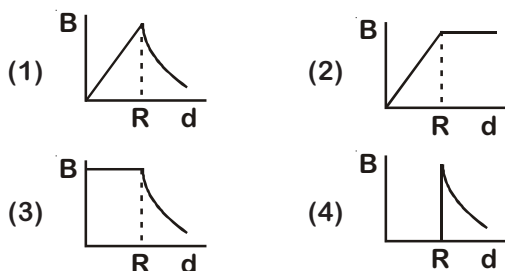

Answer (1)

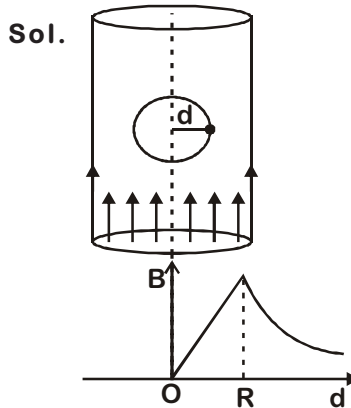

Inside ($d < R$)
 Magnetic field inside conductor

$$B = \frac{\mu_0 i}{2\pi R^2} d$$

or $B = Kd$... (i)

Straight line passing through origin

At surface ($d = R$)

$$B = \frac{\mu_0 i}{2\pi R} \quad \dots \text{(ii)}$$

Maximum at surface

Outside ($d > R$)

$$B = \frac{\mu_0 i}{2\pi d}$$

or $B \propto \frac{1}{d}$ (Hyperbolic)

117. A soap bubble, having radius of 1 mm, is blown from a detergent solution having a surface tension of $2.5 \times 10^{-2} \text{ N/m}$. The pressure inside the bubble equals at a point Z_0 below the free surface of water in a container. Taking $g = 10 \text{ m/s}^2$, density of water = 10^3 kg/m^3 , the value of Z_0 is :

- (1) 1 cm (2) 0.5 cm
 (3) 100 cm (4) 10 cm

Answer (1)

Sol. Excess pressure = $\frac{4T}{R}$, Gauge pressure

$$= \rho g Z_0$$

$$P_0 + \frac{4T}{R} = P_0 + \rho g Z_0$$

$$Z_0 = \frac{4T}{R \times \rho g}$$

$$Z_0 = \frac{4 \times 2.5 \times 10^{-2}}{10^{-3} \times 1000 \times 10} \text{ m}$$

$$Z_0 = 1 \text{ cm}$$

118. The work done to raise a mass m from the surface of the earth to a height h , which is equal to the radius of the earth, is:

- (1) $\frac{1}{2}mgR$ (2) $\frac{3}{2}mgR$
 (3) mgR (4) $2mgR$

Answer (1)

Sol.

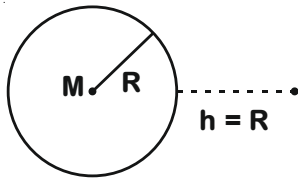

Initial potential energy at earth's surface is

$$U_i = \frac{-GMm}{R}$$

Final potential energy at height $h = R$

$$U_f = \frac{-GMm}{2R}$$

As work done = Change in PE

$$\therefore W = U_f - U_i$$

$$= \frac{GMm}{2R} = \frac{gR^2m}{2R} = \frac{mgR}{2} \quad (\because GM = gR^2)$$

119. Which of the following acts as a circuit protecting device?

- (1) Switch (2) Fuse
 (3) Conductor (4) Inductor

Answer (2)

Sol. Fuse wire has less melting point so when excess current flows, due to heat produced in it, it melts.

120. Two particles A and B are moving in uniform circular motion in concentric circles of radii r_A and r_B with speed v_A and v_B respectively. Their time period of rotation is the same. The ratio of angular speed of A to that of B will be :

- (1) $r_B : r_A$ (2) 1 : 1
 (3) $r_A : r_B$ (4) $v_A : v_B$

Answer (2)

Sol.

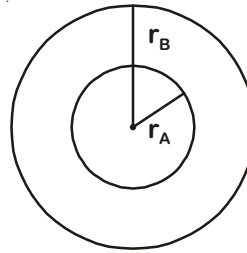

$$T_A = T_B = T$$

$$\omega_A = \frac{2\pi}{T_A}$$

$$\omega_B = \frac{2\pi}{T_B}$$

$$\frac{\omega_A}{\omega_B} = \frac{T_B}{T_A} = \frac{T}{T} = 1$$

121. A parallel plate capacitor of capacitance $20 \mu\text{F}$ is being charged by a voltage source whose potential is changing at the rate of 3 V/s . The conduction current through the connecting wires, and the displacement current through the plates of the capacitor, would be, respectively.

- (1) $60 \mu\text{A}$, zero
 (2) Zero, zero
 (3) Zero, $60 \mu\text{A}$
 (4) $60 \mu\text{A}$, $60 \mu\text{A}$

Answer (4)

Sol. Capacitance of capacitor $C = 20 \mu\text{F}$

$$= 20 \times 10^{-6} \text{ F}$$

$$\text{Rate of change of potential } \left(\frac{dV}{dt} \right) = 3 \text{ V/s}$$

$$q = CV$$

$$\frac{dq}{dt} = C \frac{dV}{dt}$$

$$i_c = 20 \times 10^{-6} \times 3$$

$$= 60 \times 10^{-6} \text{ A}$$

$$= 60 \mu\text{A}$$

As we know that $i_d = i_c = 60 \mu\text{A}$

122. The radius of circle, the period of revolution, initial position and sense of revolution are indicated in the fig.

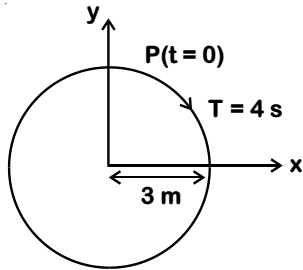

y - projection of the radius vector of rotating particle P is :

- (1) $y(t) = 3 \cos\left(\frac{3\pi t}{2}\right)$, where y in m
- (2) $y(t) = 3 \cos\left(\frac{\pi t}{2}\right)$, where y in m
- (3) $y(t) = -3 \cos 2\pi t$, where y in m
- (4) $y(t) = 4 \sin\left(\frac{\pi t}{2}\right)$, where y in m

Answer (2)

Sol. At $t = 0$, y displacement is maximum, so equation will be cosine function.

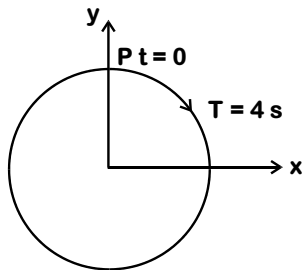

$$T = 4 \text{ s}$$

$$\omega = \frac{2\pi}{T} = \frac{2\pi}{4} = \frac{\pi}{2} \text{ rad/s}$$

$$y = a \cos \omega t$$

$$y = 3 \cos \frac{\pi}{2} t$$

123. For a p-type semiconductor, which of the following statements is true ?

- (1) Holes are the majority carriers and pentavalent atoms are the dopants.
- (2) Electrons are the majority carriers and pentavalent atoms are the dopants.
- (3) Electrons are the majority carriers and trivalent atoms are the dopants.
- (4) Holes are the majority carriers and trivalent atoms are the dopants.

Answer (4)

Sol. In p-type semiconductor, an intrinsic semiconductor is doped with trivalent impurities, that creates deficiencies of valence electrons called holes which are majority charge carriers.

124. Six similar bulbs are connected as shown in the figure with a DC source of emf E and zero internal resistance.

The ratio of power consumption by the bulbs when (i) all are glowing and (ii) in the situation when two from section A and one from section B are glowing, will be :

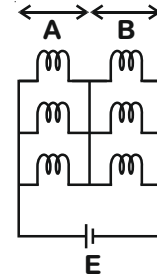

- (1) 1 : 2
- (2) 2 : 1
- (3) 4 : 9
- (4) 9 : 4

Answer (4)

Sol. (i) All bulbs are glowing

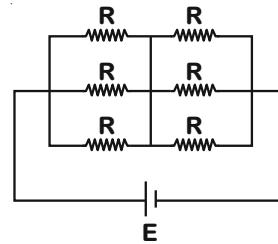

$$R_{eq} = \frac{R}{3} + \frac{R}{3} = \frac{2R}{3}$$

$$\text{Power } (P_i) = \frac{E^2}{R_{eq}} = \frac{3E^2}{2R} \quad \dots(1)$$

(ii) Two from section A and one from section B are glowing.

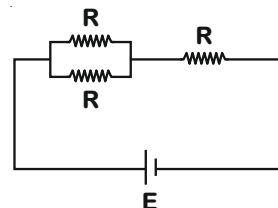

$$R_{eq} = \frac{R}{2} + R = \frac{3R}{2}$$

$$\text{Power } (P_f) = \frac{2E^2}{3R} \quad \dots(2)$$

$$\frac{P_i}{P_f} = \frac{3E^2}{2R} \cdot \frac{3R}{2E^2} = 9 : 4$$

125. Increase in temperature of a gas filled in a container would lead to :

- (1) Decrease in its pressure
- (2) Decrease in intermolecular distance
- (3) Increase in its mass
- (4) Increase in its kinetic energy

Answer (4)

Sol. Increase in temperature would lead to the increase in kinetic energy of gas (assuming

far as to be ideal) as $U = \frac{F}{2}nRT$

126. In a double slit experiment, when light of wavelength 400 nm was used, the angular width of the first minima formed on a screen placed 1 m away, was found to be 0.2° . What will be the angular width of the first minima, if the entire experimental apparatus is immersed in water? ($\mu_{\text{water}} = 4/3$)

- (1) 0.05°
- (2) 0.1°
- (3) 0.266°
- (4) 0.15°

Answer (4)

Sol. In air angular fringe width $\theta_0 = \frac{\beta}{D}$

Angular fringe width in water

$$\theta_w = \frac{\beta}{\mu D} = \frac{\theta_0}{\mu}$$

$$= \frac{0.2^\circ}{\left(\frac{4}{3}\right)} = 0.15^\circ$$

127. The total energy of an electron in an atom in an orbit is -3.4 eV. Its kinetic and potential energies are, respectively:

- (1) 3.4 eV, -6.8 eV
- (2) 3.4 eV, 3.4 eV
- (3) -3.4 eV, -3.4 eV
- (4) -3.4 eV, -6.8 eV

Answer (1)

Sol. In Bohr's model of H atom

$$\therefore \text{K.E.} = |\text{TE}| = \frac{|U|}{2}$$

$$\therefore \text{K.E.} = 3.4 \text{ eV}$$

$$U = -6.8 \text{ eV}$$

128. Which colour of the light has the longest wavelength?

- (1) Green
- (2) Violet
- (3) Red
- (4) Blue

Answer (3)

Sol. Red has the longest wavelength among the given options.

129. In total internal reflection when the angle of incidence is equal to the critical angle for the pair of media in contact, what will be angle of refraction?

- (1) Equal to angle of incidence
- (2) 90°
- (3) 180°
- (4) 0°

Answer (2)

Sol.

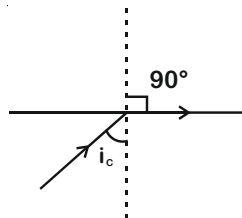

At $i = i_c$, refracted ray grazes with the surface.

So angle of refraction is 90° .

130. A disc of radius 2 m and mass 100 kg rolls on a horizontal floor. Its centre of mass has speed of 20 cm/s. How much work is needed to stop it?

- (1) 2 J
- (2) 1 J
- (3) 3 J
- (4) 30 kJ

Answer (3)

Sol. Work required = change in kinetic energy

Final KE = 0

$$\text{Initial KE} = \frac{1}{2}mv^2 + \frac{1}{2}I\omega^2 = \frac{3}{4}mv^2$$

$$= \frac{3}{4} \times 100 \times (20 \times 10^{-2})^2 = 3 \text{ J}$$

$$|\Delta \text{KE}| = 3 \text{ J}$$

131. When a block of mass M is suspended by a long wire of length L, the length of the wire becomes (L + l). The elastic potential energy stored in the extended wire is :

- (1) $\frac{1}{2}Mgl$
- (2) $\frac{1}{2}MgL$
- (3) Mgl
- (4) MgL

Answer (1)

Sol.

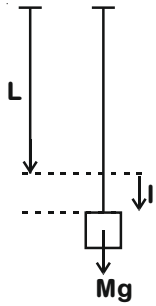

$$U = \frac{1}{2} \text{ (work done by gravity)}$$

$$U = \frac{1}{2} Mgl$$

132. A solid cylinder of mass 2 kg and radius 4 cm is rotating about its axis at the rate of 3 rpm. The torque required to stop after 2π revolutions is

- (1) 12×10^{-4} N m (2) 2×10^6 N m
 (3) 2×10^{-6} N m (4) 2×10^{-3} N m

Answer (3)

Sol. Work energy theorem.

$$W = \frac{1}{2} I(\omega_f^2 - \omega_i^2) \quad \theta = 2\pi \text{ revolution}$$

$$= 2\pi \times 2\pi = 4\pi^2 \text{ rad}$$

$$\omega_i = 3 \times \frac{2\pi}{60} \text{ rad/s}$$

$$\Rightarrow -\tau\theta = \frac{1}{2} \times \frac{1}{2} mr^2 (\omega_f^2 - \omega_i^2)$$

$$\Rightarrow -\tau = \frac{\frac{1}{2} \times \frac{1}{2} \times 2 \times (4 \times 10^{-2}) \left(-3 \times \frac{2\pi}{60} \right)^2}{4\pi^2}$$

$$\Rightarrow \tau = 2 \times 10^{-6} \text{ N m}$$

133. Two point charges A and B, having charges $+Q$ and $-Q$ respectively, are placed at certain distance apart and force acting between them is F . If 25% charge of A is transferred to B, then force between the charges becomes :

- (1) $\frac{16F}{9}$ (2) $\frac{4F}{3}$
 (3) F (4) $\frac{9F}{16}$

Answer (4)

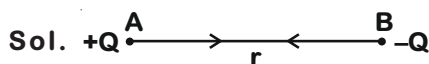

$$F = \frac{kQ^2}{r^2}$$

If 25% of charge of A transferred to B then

$$q_A = Q - \frac{Q}{4} = \frac{3Q}{4} \text{ and } q_B = -Q + \frac{Q}{4} = \frac{-3Q}{4}$$

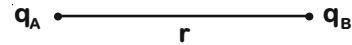

$$F_1 = \frac{kq_A q_B}{r^2}$$

$$F_1 = \frac{k \left(\frac{3Q}{4} \right)^2}{r^2}$$

$$F_1 = \frac{9}{16} \frac{kQ^2}{r^2}$$

$$F_1 = \frac{9F}{16}$$

134. Pick the wrong answer in the context with rainbow.

- (1) An observer can see a rainbow when his front is towards the sun
 (2) Rainbow is a combined effect of dispersion refraction and reflection of sunlight
 (3) When the light rays undergo two internal reflections in a water drop, a secondary rainbow is formed
 (4) The order of colours is reversed in the secondary rainbow

Answer (1)

Sol. Rainbow can't be observed when observer faces towards sun.

135. A copper rod of 88 cm and an aluminium rod of unknown length have their increase in length independent of increase in temperature. The length of aluminium rod is : ($\alpha_{Cu} = 1.7 \times 10^{-5} \text{ K}^{-1}$ and $\alpha_{Al} = 2.2 \times 10^{-5} \text{ K}^{-1}$)

- (1) 88 cm (2) 68 cm
 (3) 6.8 cm (4) 113.9 cm

Answer (2)

$$\text{Sol. } \alpha_{Cu} L_{Cu} = \alpha_{Al} L_{Al}$$

$$1.7 \times 10^{-5} \times 88 \text{ cm} = 2.2 \times 10^{-5} \times L_{Al}$$

$$L_{Al} = \frac{1.7 \times 88}{2.2} = 68 \text{ cm}$$

136. In which case change in entropy is negative?
- (1) Sublimation of solid to gas
 - (2) $2\text{H}(\text{g}) \rightarrow \text{H}_2(\text{g})$
 - (3) Evaporation of water
 - (4) Expansion of a gas at constant temperature

Answer (2)

Sol. • $\text{H}_2\text{O}(\ell) \rightleftharpoons \text{H}_2\text{O}(\text{v}), \Delta S > 0$

- Expansion of gas at constant temperature, $\Delta S > 0$
- Sublimation of solid to gas, $\Delta S > 0$
- $2\text{H}(\text{g}) \rightarrow \text{H}_2(\text{g}), \Delta S < 0 (\because \Delta n_g < 0)$

137. For the chemical reaction

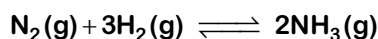

The correct option is:

- (1) $-\frac{d[\text{N}_2]}{dt} = \frac{1}{2} \frac{d[\text{NH}_3]}{dt}$
- (2) $3 \frac{d[\text{H}_2]}{dt} = 2 \frac{d[\text{NH}_3]}{dt}$
- (3) $-\frac{1}{3} \frac{d[\text{H}_2]}{dt} = -\frac{1}{2} \frac{d[\text{NH}_3]}{dt}$
- (4) $-\frac{d[\text{N}_2]}{dt} = 2 \frac{d[\text{NH}_3]}{dt}$

Answer (1)

Sol. $\text{N}_2 + 3\text{H}_2 \rightleftharpoons 2\text{NH}_3$

Rate of reaction is given as

$$-\frac{d[\text{N}_2]}{dt} = -\frac{1}{3} \frac{d[\text{H}_2]}{dt} = +\frac{1}{2} \frac{d[\text{NH}_3]}{dt}$$

138. Which of the following diatomic molecular species has only π bonds according to Molecular Orbital Theory?
- (1) C_2
 - (2) Be_2
 - (3) O_2
 - (4) N_2

Answer (1)

Sol. MO configuration C_2 is:

$$\sigma 1s^2, \sigma^* 1s^2, \sigma 2s^2, \sigma^* 2s^2, \pi 2p_x^2 = \pi 2p_y^2$$

139. Which of the following is incorrect statement?

- (1) GeX_4 ($\text{X} = \text{F}, \text{Cl}, \text{Br}, \text{I}$) is more stable than GeX_2
- (2) SnF_4 is ionic in nature
- (3) PbF_4 is covalent in nature
- (4) SiCl_4 is easily hydrolysed

Answer (3)

Sol. PbF_4 and SnF_4 are ionic in nature.

140. Under isothermal condition, a gas at 300 K expands from 0.1 L to 0.25 L against a constant external pressure of 2 bar. The work done by the gas is

(Given that 1 L bar = 100 J)

- (1) 25 J
- (2) 30 J
- (3) -30 J
- (4) 5 kJ

Answer (3)

Sol. $\therefore W_{\text{irr}} = -P_{\text{ext}} \Delta V$
 $= -2 \text{ bar} \times (0.25 - 0.1) \text{ L}$
 $= -2 \times 0.15 \text{ L-bar}$
 $= -0.30 \text{ L-bar}$
 $= -0.30 \times 100 \text{ J}$
 $= -30 \text{ J}$

141. The compound that is most difficult to protonate is :

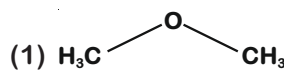
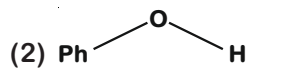
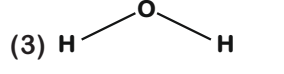
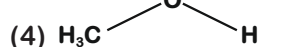
- (1) 
- (2) 
- (3) 
- (4) 

Answer (2)

Sol. Due to involvement of lone pair of electrons in resonance in phenol, it will have positive charge (partial), hence incoming proton will not be able to attack easily.

142. Which of the following is an amphoteric hydroxide?

- (1) $\text{Mg}(\text{OH})_2$
- (2) $\text{Be}(\text{OH})_2$
- (3) $\text{Sr}(\text{OH})_2$
- (4) $\text{Ca}(\text{OH})_2$

Answer (2)

Sol. $\text{Be}(\text{OH})_2$ amphoteric in nature, since it can react both with acid and base

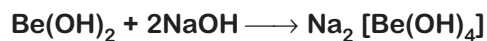
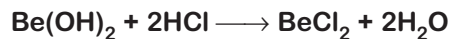

143. The correct structure of tribromooctaoxide is

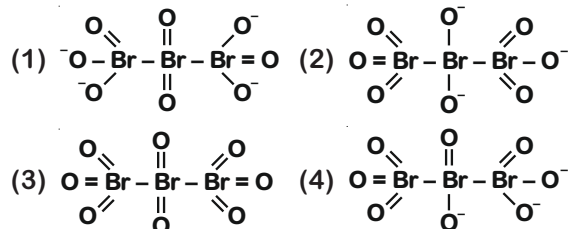

Answer (3)

Sol. The correct structure is

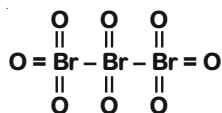

Tribromooctaoxide

144. The biodegradable polymer is:

- (1) Nylon-6 (2) Buna-S
(3) Nylon-6,6 (4) Nylon-2-Nylon 6

Answer (4)

Sol. Nylon-2-Nylon 6

145. Among the following, the reaction that proceeds through an electrophilic substitution, is:

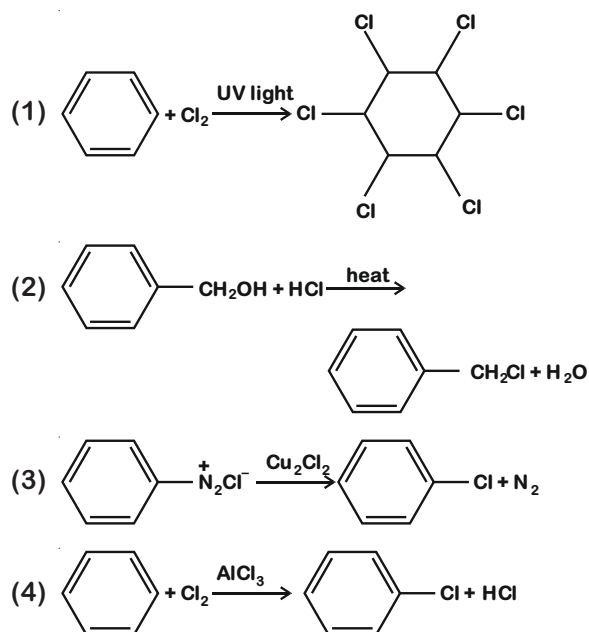

Answer (4)

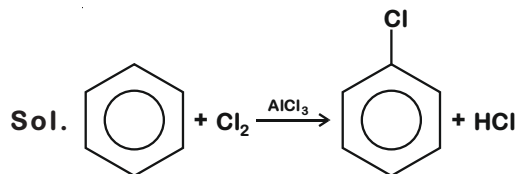

Generation of electrophile:

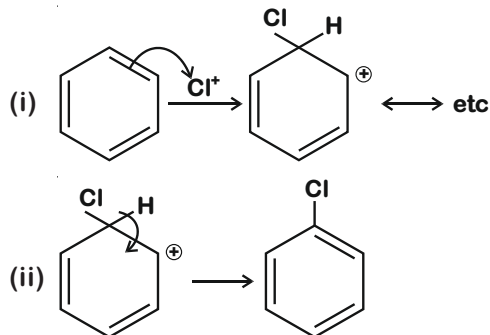
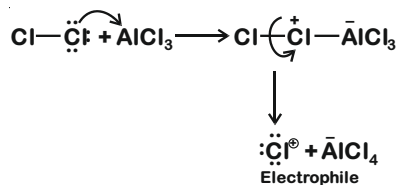

146. Match the following :

- (a) Pure nitrogen (i) Chlorine
(b) Haber process (ii) Sulphuric acid
(c) Contact process (iii) Ammonia
(d) Deacon's process (iv) Sodium azide or Barium azide

Which of the following is the correct option?

- (a) (b) (c) (d)
(1) (iii) (iv) (ii) (i)
(2) (iv) (iii) (ii) (i)
(3) (i) (ii) (iii) (iv)
(4) (ii) (iv) (i) (iii)

Answer (2)

Sol. (a) Pure nitrogen : Sodium azide or Barium azide
(b) Haber process : Ammonia
(c) Contact process : Sulphuric acid
(d) Deacon's process : Chlorine

147. The number of sigma (σ) and pi (π) bonds in pent-2-en-4-yne is

- (1) 11σ bonds and 2π bonds
(2) 13σ bonds and no π bonds
(3) 10σ bonds and 3π bonds
(4) 8σ bonds and 5π bonds

Answer (3)

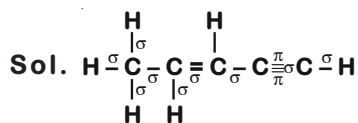

Number of σ bonds = 10

and number of π bonds = 3

148. Enzymes that utilize ATP in phosphate transfer require an alkaline earth metal (M) as the cofactor. M is :

- (1) Ca (2) Sr
(3) Be (4) Mg

Answer (4)

Sol. All enzymes that utilize ATP in phosphate transfer require magnesium (Mg) as the co-factor.

149. Identify the incorrect statement related to PCl_5 from the following:

- (1) Axial P-Cl bonds are longer than equatorial P-Cl bonds
(2) PCl_5 molecule is non-reactive
(3) Three equatorial P-Cl bonds make an angle of 120° with each other
(4) Two axial P-Cl bonds make an angle of 180° with each other

Answer (2)

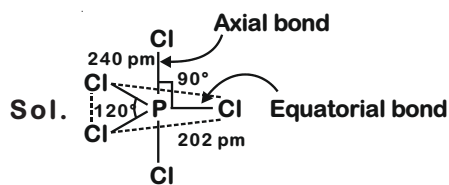

(1) True

Axial bond : 240 pm

Equatorial bond : 202 pm

(2) False

Due to longer and hence weaker axial bonds, PCl_5 is a reactive molecule.

(3) True

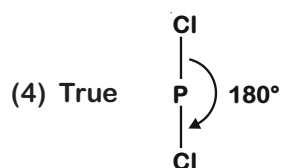

150. If the rate constant for a first order reaction is k , the time (t) required for the completion of 99% of the reaction is given by:

- (1) $t = 4.606/k$ (2) $t = 2.303/k$
(3) $t = 0.693/k$ (4) $t = 6.909/k$

Answer (1)

Sol. First order rate constant is given as,

$$k = \frac{2.303}{t} \log \frac{[A_0]}{[A]_t}$$

99% completed reaction,

$$k = \frac{2.303}{t} \log \frac{100}{1}$$

$$= \frac{2.303}{t} \log 10^2$$

$$k = \frac{2.303}{t} \times 2 \log 10$$

$$t = \frac{2.303}{k} \times 2 = \frac{4.606}{k}$$

$$t = \frac{4.606}{k}$$

151. The most suitable reagent for the following conversion, is :

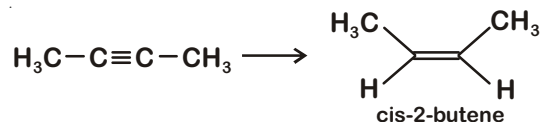

- (1) Zn/HCl (2) $\text{Hg}^{2+}/\text{H}^+$, H_2O
(3) Na/liquid NH_3 (4) H_2 , Pd/C, quinoline

Answer (4)

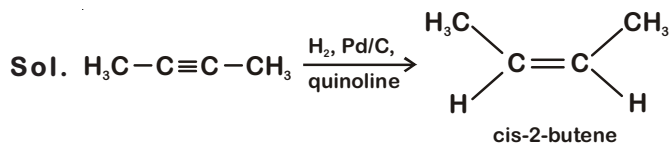

152. The manganate and permanganate ions are tetrahedral, due to :

- (1) The π -bonding involves overlap of p-orbitals of oxygen with p-orbitals of manganese
(2) The π -bonding involves overlap of d-orbitals of oxygen with d-orbitals of manganese
(3) The π -bonding involves overlap of p-orbitals of oxygen with d-orbitals of manganese
(4) There is no π -bonding

Answer (3)

Sol. • Manganate (MnO_4^{2-}):

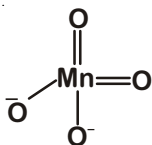

⇒ π -bonds are of $d\pi$ - $p\pi$ type

• Permanganate (MnO_4^-):

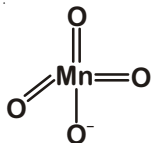

⇒ π -bonds are of $d\pi$ - $p\pi$ type

153. For a cell involving one electron $E^\circ_{\text{cell}} = 0.59 \text{ V}$ at 298 K, the equilibrium constant for the cell reaction is :

$$\left[\text{Given that } \frac{2.303 RT}{F} = 0.059 \text{ V at } T = 298 \text{ K} \right]$$

- (1) 1.0×10^{10}
- (2) 1.0×10^{30}
- (3) 1.0×10^2
- (4) 1.0×10^5

Answer (1)

Sol. $E_{\text{cell}} = E^\circ_{\text{cell}} - \frac{0.059}{n} \log Q$... (i)

(At equilibrium, $Q = K_{\text{eq}}$ and $E_{\text{cell}} = 0$)

$$0 = E^\circ_{\text{cell}} - \frac{0.059}{1} \log K_{\text{eq}} \text{ (from equation (i))}$$

$$\log K_{\text{eq}} = \frac{E^\circ_{\text{cell}}}{0.059} = \frac{0.59}{0.059} = 10$$

$$K_{\text{eq}} = 10^{10} = 1 \times 10^{10}$$

154. pH of a saturated solution of Ca(OH)_2 is 9. The solubility product (K_{sp}) of Ca(OH)_2 is:

- (1) 0.125×10^{-15}
- (2) 0.5×10^{-10}
- (3) 0.5×10^{-15}
- (4) 0.25×10^{-10}

Answer (3)

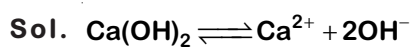

pH = 9 Hence pOH = 14 - 9 = 5
[OH⁻] = 10^{-5} M

$$\text{Hence } [\text{Ca}^{2+}] = \frac{10^{-5}}{2}$$

$$\text{Thus } K_{\text{sp}} = [\text{Ca}^{2+}][\text{OH}^-]^2$$

$$= \left(\frac{10^{-5}}{2} \right) (10^{-5})^2$$
$$= 0.5 \times 10^{-15}$$

155. For an ideal solution, the correct option is :

- (1) $\Delta_{\text{mix}} H = 0$ at constant T and P
- (2) $\Delta_{\text{mix}} G = 0$ at constant T and P
- (3) $\Delta_{\text{mix}} S = 0$ at constant T and P
- (4) $\Delta_{\text{mix}} V \neq 0$ at constant T and P

Answer (1)

Sol. For ideal solution,

$$\Delta_{\text{mix}} H = 0$$

$$\Delta_{\text{mix}} S > 0$$

$$\Delta_{\text{mix}} G < 0$$

$$\Delta_{\text{mix}} V = 0$$

156. A gas at 350 K and 15 bar has molar volume 20 percent smaller than that for an ideal gas under the same conditions. The correct option about the gas and its compressibility factor (Z) is :

- (1) $Z < 1$ and attractive forces are dominant
- (2) $Z < 1$ and repulsive forces are dominant
- (3) $Z > 1$ and attractive forces are dominant
- (4) $Z > 1$ and repulsive forces are dominant

Answer (1)

Sol. • Compressibility factor (Z) = $\frac{V_{\text{real}}}{V_{\text{ideal}}}$

$$\therefore V_{\text{real}} < V_{\text{ideal}}; \text{ Hence } Z < 1$$

• If $Z < 1$, attractive forces are dominant among gaseous molecules and liquefaction of gas will be easy.

157. The correct order of the basic strength of methyl substituted amines in aqueous solution is :

- (1) $(\text{CH}_3)_3\text{N} > (\text{CH}_3)_2\text{NH} > \text{CH}_3\text{NH}_2$
- (2) $\text{CH}_3\text{NH}_2 > (\text{CH}_3)_2\text{NH} > (\text{CH}_3)_3\text{N}$
- (3) $(\text{CH}_3)_2\text{NH} > \text{CH}_3\text{NH}_2 > (\text{CH}_3)_3\text{N}$
- (4) $(\text{CH}_3)_3\text{N} > \text{CH}_3\text{NH}_2 > (\text{CH}_3)_2\text{NH}$

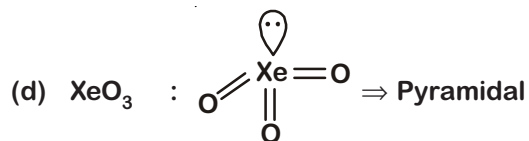
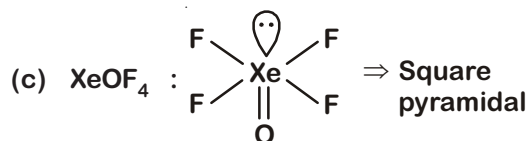
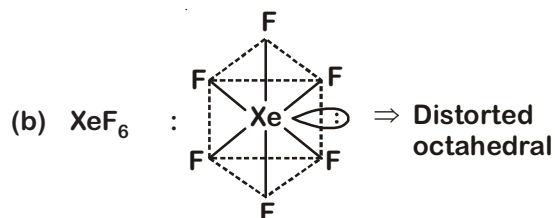

169. Among the following, the one that is not a green house gas is

- (1) Ozone (2) Sulphur dioxide
(3) Nitrous oxide (4) Methane

Answer (2)

Sol. Fact

SO_2 (g) is not a greenhouse gas.

170. Which of the following reactions are disproportionation reaction?

- (a) $2\text{Cu}^+ \longrightarrow \text{Cu}^{2+} + \text{Cu}^0$
(b) $3\text{MnO}_4^{2-} + 4\text{H}^+ \longrightarrow 2\text{MnO}_4^- + \text{MnO}_2 + 2\text{H}_2\text{O}$
(c) $2\text{KMnO}_4 \xrightarrow{\Delta} \text{K}_2\text{MnO}_4 + \text{MnO}_2 + \text{O}_2$
(d) $2\text{MnO}_4^- + 3\text{Mn}^{2+} + 2\text{H}_2\text{O} \longrightarrow 5\text{MnO}_2 + 4\text{H}^{\oplus}$

Select the correct option from the following

- (1) (a), (c) and (d) (2) (a) and (d) only
(3) (a) and (b) only (4) (a), (b) and (c)

Answer (3)

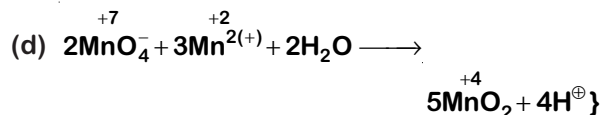
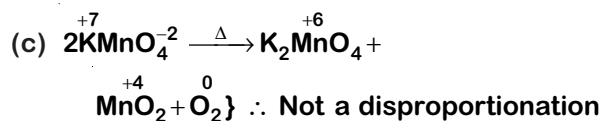
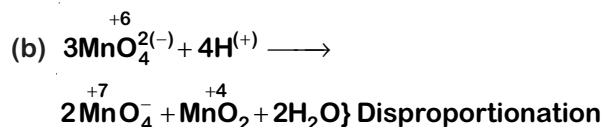
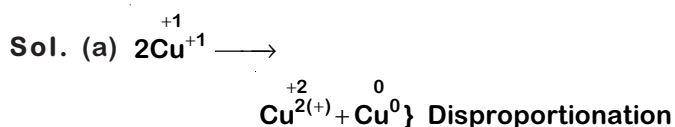

171. The structure of intermediate A in the following reaction, is

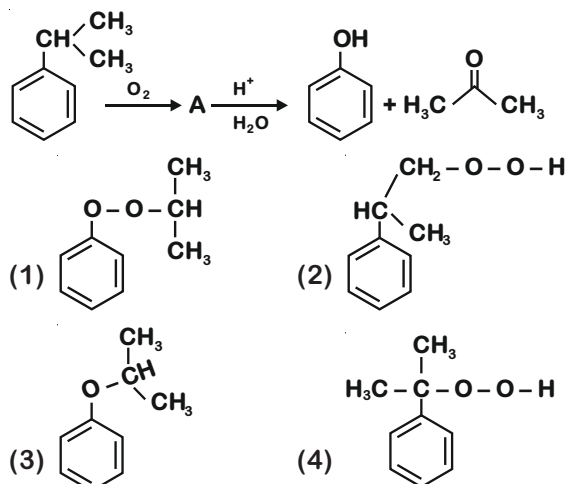

Answer (4)

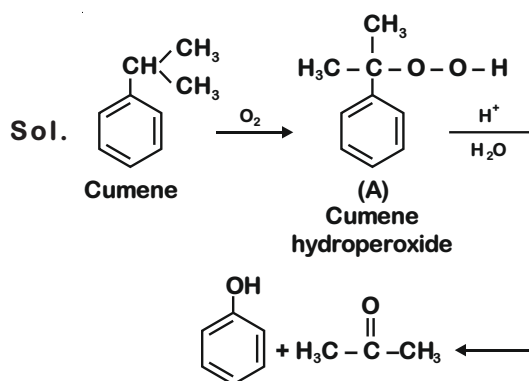

172. The mixture that forms maximum boiling azeotrope is:

- (1) Acetone + Carbon disulphide
(2) Heptane + Octane
(3) Water + Nitric acid
(4) Ethanol + Water

Answer (3)

Sol. Solutions showing negative deviation from Raoult's law form maximum boiling azeotrope
Water and Nitric acid \rightarrow forms maximum boiling azeotrope

173. What is the correct electronic configuration of the central atom in $\text{K}_4[\text{Fe}(\text{CN})_6]$ based on crystal field theory?

- (1) $e^3 t_2^3$ (2) $e^4 t_2^2$
(3) $t_{2g}^4 e_g^2$ (4) $t_{2g}^6 e_g^0$

Answer (4)

Sol. $K_4[Fe(CN)_6]$

Fe ground state: $[Ar]3d^64s^2$

Fe^{2+} : $3d^64s^0$

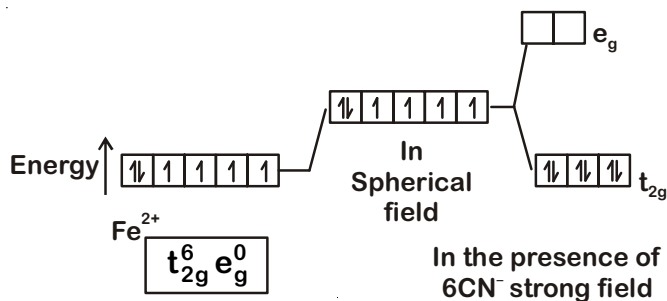

174. Conjugate base for Brönsted acids H_2O and HF are :

- (1) OH^- and F^- , respectively
- (2) H_3O^+ and H_2F^+ , respectively
- (3) OH^- and H_2F^+ , respectively
- (4) H_3O^+ and F^- , respectively

Answer (1)

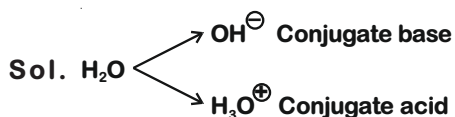

HF on loss of H^\oplus ion becomes F^\ominus is the conjugate base of HF

Example :

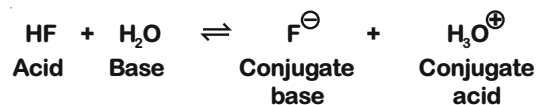

175. Which will make basic buffer?

- (1) 100 mL of 0.1 M HCl + 200 mL of 0.1 M NH_4OH
- (2) 100 mL of 0.1 M HCl + 100 mL of 0.1 M $NaOH$
- (3) 50 mL of 0.1 M $NaOH$ + 25 mL of 0.1 M CH_3COOH
- (4) 100 mL of 0.1 M CH_3COOH + 100 mL of 0.1 M $NaOH$

Answer (1)

Sol.

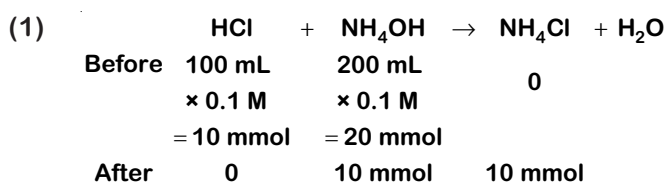

This is basic buffer

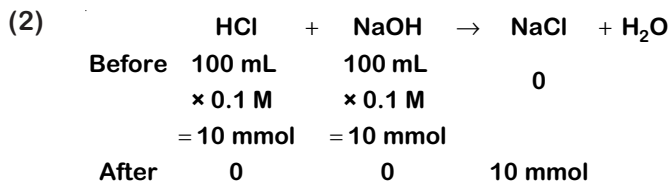

\Rightarrow Neutral solution

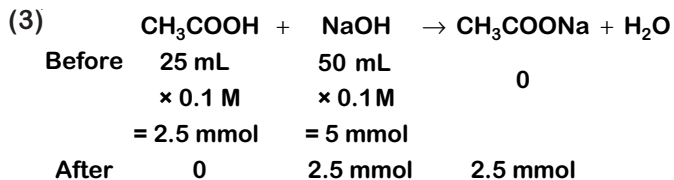

This is basic solution due to $NaOH$.

This is not basic buffer.

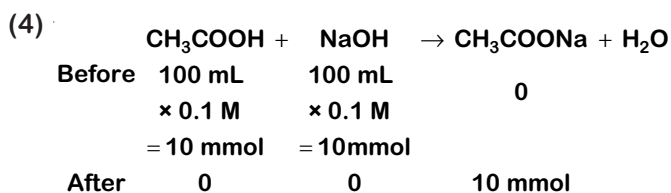

Hydrolysis of salt takes place.

This is not basic buffer.

176. 4d, 5p, 5f and 6p orbitals are arranged in the order of decreasing energy. The correct option is

- (1) $6p > 5f > 4d > 5p$
- (2) $5f > 6p > 4d > 5p$
- (3) $5f > 6p > 5p > 4d$
- (4) $6p > 5f > 5p > 4d$

Answer (3)

Sol. $(n + l)$ values for, $4d = 4 + 2 = 6$

$$5p = 5 + 1 = 6$$

$$5f = 5 + 3 = 8$$

$$6p = 6 + 1 = 7$$

\therefore Correct order of energy would be

$$5f > 6p > 5p > 4d$$

177. Among the following, the narrow spectrum antibiotic is :

- (1) Amoxycillin
- (2) Chloramphenicol
- (3) Penicillin G
- (4) Ampicillin

Answer (3)

Sol. Penicillin G

178. The major product of the following reaction is:

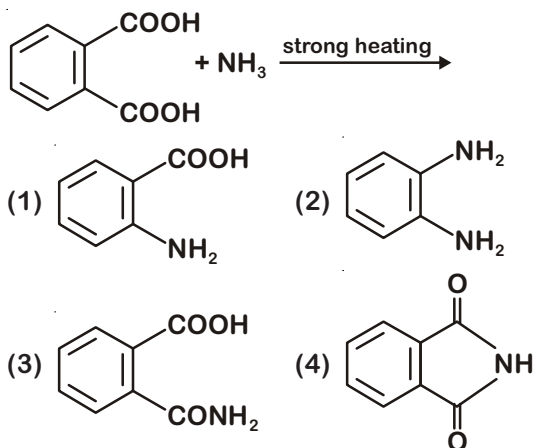

Answer (4)

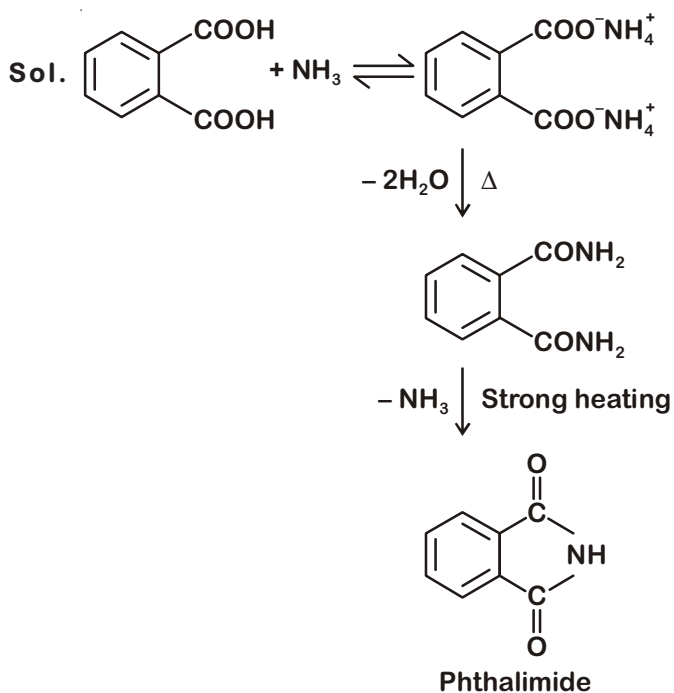

179. The method used to remove temporary hardness of water is :

- (1) Ion-exchange method
- (2) Synthetic resins method
- (3) Calgon's method
- (4) Clark's method

Answer (4)

Sol. Clark's method is used to remove temporary hardness of water, in which bicarbonates of calcium and magnesium are reacted with slaked lime Ca(OH)_2

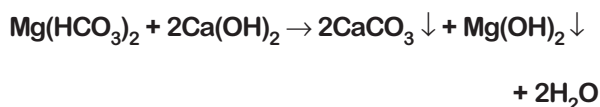
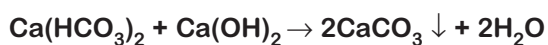

180. Which one is malachite from the following?

- (1) Fe_3O_4
- (2) $\text{CuCO}_3 \cdot \text{Cu(OH)}_2$
- (3) CuFeS_2
- (4) Cu(OH)_2

Answer (2)

Sol. Malachite : $\text{CuCO}_3 \cdot \text{Cu(OH)}_2$ (Green colour)



CODE: S2 – Answer Key:

| | | | | | | | | | |
|----------|----------|----------|----------|----------|----------|----------|----------|------------|----------|
| 1. (1) | 2. (3) | 3. (4) | 4. (4) | 5. (4) | 6. (1) | 7. (4) | 8. (3) | 9. (3) | 10. (2) |
| 11. (1) | 12. (4) | 13. (1) | 14. (4) | 15. (4) | 16. (3) | 17. (1) | 18. (4) | 19. (1) | 20. (4) |
| 21. (1) | 22. (2) | 23. (2) | 24. (4) | 25. (2) | 26. (1) | 27. (3) | 28. (1) | 29. (2) | 30. (2) |
| 31. (2) | 32. (4) | 33. (1) | 34. (2) | 35. (2) | 36. (3) | 37. (4) | 38. (2) | 39. (3) | 40. (3) |
| 41. (3) | 42. (4) | 43. (4) | 44. (2) | 45. (2) | 46. (2) | 47. (4) | 48. (3) | 49. (2) | 50. (4) |
| 51. (4) | 52. (2) | 53. (1) | 54. (4) | 55. (4) | 56. (4) | 57. (4) | 58. (1) | 59. (1) | 60. (3) |
| 61. (1) | 62. (2) | 63. (2) | 64. (4) | 65. (1) | 66. (3) | 67. (1) | 68. (2) | 69. (2) | 70. (2) |
| 71. (4) | 72. (1) | 73. (2) | 74. (4) | 75. (1) | 76. (3) | 77. (4) | 78. (2) | 79. (1) | 80. (3) |
| 81. (2) | 82. (2) | 83. (1) | 84. (1) | 85. (4) | 86. (2) | 87. (1) | 88. (3) | 89. (4) | 90. (1) |
| 91. (2) | 92. (4) | 93. (1) | 94. (3) | 95. (4) | 96. (3) | 97. (1) | 98. (2) | 99. (1) | 100. (4) |
| 101. (4) | 102. (3) | 103. (4) | 104. (4) | 105. (1) | 106. (4) | 107. (2) | 108. (2) | 109. (2) | 110. (1) |
| 111. (1) | 112. (1) | 113. (1) | 114. (3) | 115. (1) | 116. (1) | 117. (1) | 118. (1) | 119. (2) | 120. (2) |
| 121. (4) | 122. (2) | 123. (4) | 124. (4) | 125. (4) | 126. (4) | 127. (1) | 128. (3) | 129. (2) | 130. (3) |
| 131. (1) | 132. (3) | 133. (4) | 134. (1) | 135. (2) | 136. (2) | 137. (1) | 138. (1) | 139. (3) | 140. (3) |
| 141. (2) | 142. (2) | 143. (3) | 144. (4) | 145. (4) | 146. (2) | 147. (3) | 148. (4) | 149. (2) | 150. (1) |
| 151. (4) | 152. (3) | 153. (1) | 154. (3) | 155. (1) | 156. (1) | 157. (3) | 158. (4) | 159. (3,4) | 160. (3) |
| 161. (1) | 162. (1) | 163. (4) | 164. (1) | 165. (1) | 166. (1) | 167. (2) | 168. (4) | 169. (2) | 170. (3) |
| 171. (4) | 172. (3) | 173. (4) | 174. (1) | 175. (1) | 176. (3) | 177. (3) | 178. (4) | 179. (4) | 180. (2) |